

## Box content

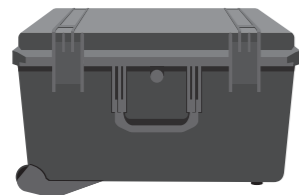

Lyve Mobile Array



Shipping case



Power adapter



Magnetic labels (X3)

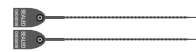

Security ties (X2)

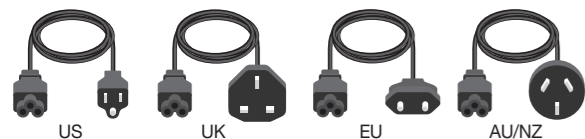

Power cords (x4)



Thunderbolt™ 3 cable (up to 40Gb/s)  
USB-C to USB-C cable (USB 3.1 Gen 2, up to 10Gb/s)  
USB-C to USB-A cable (USB 3.1 Gen 1, up to 5Gb/s and compatible with USB 3.0 ports)

## Lyve™ Mobile Security

Lyve Mobile offers two ways for project admins to manage how end users securely access Lyve Mobile storage devices:

### Lyve Portal Identity

End users authorize client computers to access Lyve Mobile devices using their Lyve Management Portal credentials. Requires an internet connection for initial setup and periodic reauthorization through Lyve Management Portal.

### Lyve Token Security

End users are provided with Lyve Token files that can be installed on certified client computers and Lyve Mobile Padlock devices. Once configured, computers/Padlock devices unlocking Lyve Mobile devices do not require continual access to Lyve Management Portal or the internet.



For details on setting up security, go to [www.seagate.com/lyve-security](http://www.seagate.com/lyve-security)



[www.seagate.com/support/mobile-array](http://www.seagate.com/support/mobile-array)

## Connection options

 Lyve Mobile Array can be used as direct-attached storage. See the following steps in this quick start guide.

 Lyve Mobile Array can also support connections via Fibre Channel, iSCSI and SAS using the Lyve Mobile Rackmount Receiver. For details, go to: [www.seagate.com/manuals/rackmount-receiver](http://www.seagate.com/manuals/rackmount-receiver).

 For high-speed mobile data transfers, connect Lyve Mobile Array using the Lyve Mobile PCIe Adapter. See [www.seagate.com/manuals/pcie-adapter](http://www.seagate.com/manuals/pcie-adapter).

## Ports

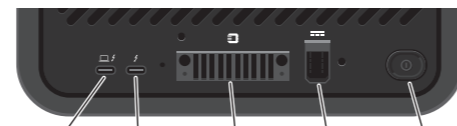

A Thunderbolt™ 3 (host)  
B Thunderbolt™ 3 (peripheral)  
C Lyve USM™ Connector (High Performance PCIe gen 3.0)  
D Power input  
Power button

## Data ports

 **Direct-attached storage (DAS): A, B**

 **Rackmount Receiver: C**

 **PCIe Adapter: C**

## 1 Connect power

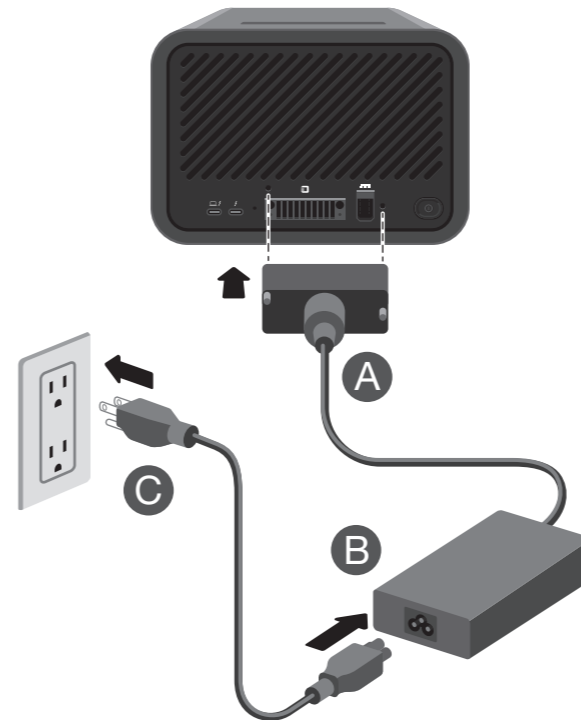

## 2 Connect to computer

**Make sure Lyve Mobile Array is powered on before connecting it to a computer.** Lyve Mobile Array is shipped with three types of cables to connect to host computers. Please review the table below for cable and host port options.

Cable	Host Port
Thunderbolt™ 3	Thunderbolt 3/4
USB-C to USB-C	USB 3.1 Gen 1 or higher
USB-C to USB-A	USB 3.0 or higher

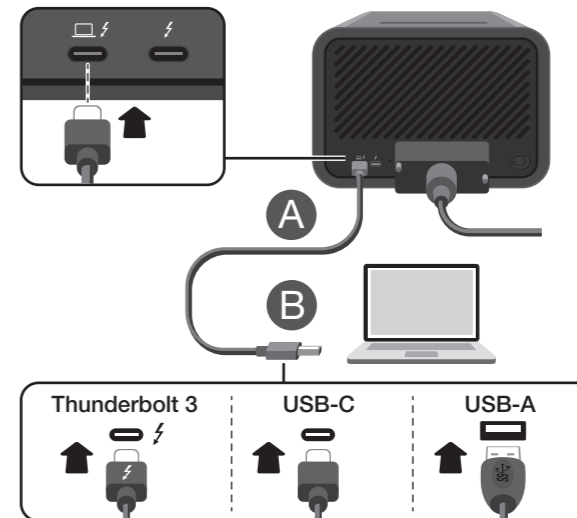

## 3 Unlock the device

The LED on the device blinks white during the boot process and turns solid orange. The solid orange LED color indicates the device is ready to be unlocked.

Once the device has been unlocked by a valid Lyve Portal Identity or Lyve Token file, the LED on the device turns solid green. The device is ready for use.



### Amber LED

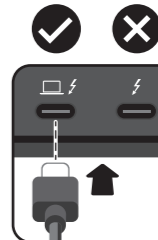

If you are using a USB host and the Lyve Mobile Array status LED is illuminated with an amber chase pattern, make sure the cable is connected to Lyve Mobile Array's Thunderbolt 3/USB-C host port. **The host port is the USB-C port with the computer icon.** An amber chase pattern indicates that the computer is connected to the peripheral port.

## Power button

**Power on:** A connection to a computer is not required to power on Lyve Mobile Array. It automatically powers on when connected to a power outlet.

**Power off:** Before powering off Lyve Mobile Array, make certain to safely eject its volumes from the host computer. Apply a long press (3 seconds) to the power button to turn off Lyve Mobile Array.



If Lyve Mobile Array is off but still connected to power, you can turn Lyve Mobile Array back on by applying a short press (1 second) to the power button.



## Magnetic Labels

Magnetic labels can be placed on the front of Lyve Mobile Array to help identify individual devices. Use a marker or grease pencil to customize the labels

A

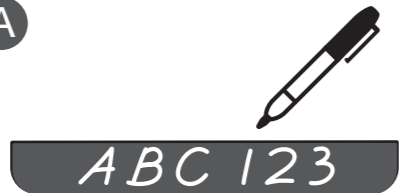

B

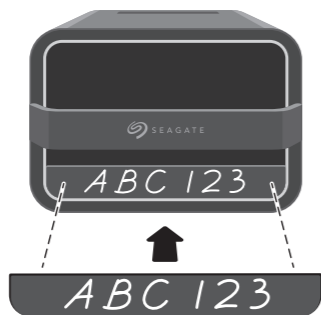

## Lyve Mobile Shipper

A shipping case is included with Lyve Mobile Array. **Always use the case when transporting and shipping Lyve Mobile Array.**

For additional security, fasten the included beaded security tie to Lyve Mobile Shipper. The recipient knows the case was not tampered with in transit if the tie remains intact.

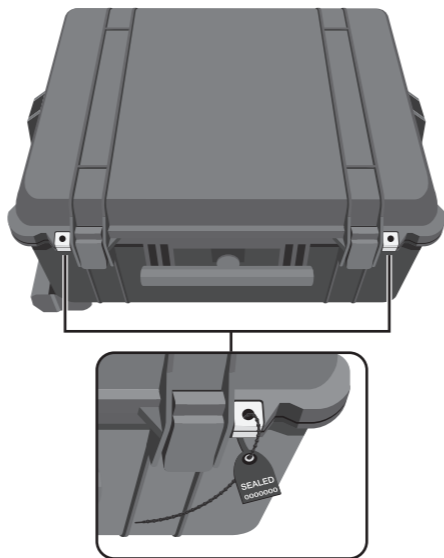

### China RoHS 2 table

China RoHS 2 refers to the Ministry of Industry and Information Technology Order No. 32, effective July 1, 2016, titled Management Methods for the Restriction of the Use of Hazardous Substances in Electrical and Electronic Products. To comply with China RoHS 2, we determined this product's Environmental Protection Use Period (EUP) to be 20 years in accordance with the Marking for the Restricted Use of Hazardous Substances in Electronic and Electrical Products, SJ/T 11364-2014.

中国 RoHS 2 是指 2016 年 7 月 1 日起施行的工业和信息化部令 32 号“电力电子产品限制使用有害物质管理办法”。为了符合中国 RoHS 2 的要求，我们根据“电子电气产品有害物质限制使用标识”（SJ/T 11364-2014）确定本产品的环保使用期（EUP）为 20 年。

部件名称 Part Name	有害物质 Hazardous Substances					
	铅 (Pb)	汞 (Hg)	镉 (Cd)	六价铬 (Cr <sup>VI</sup> )	多溴联苯 (PBB)	多溴二苯醚 (PBDE)
硬盘驱动器/固态硬盘 HDD/SSD	X	0	0	0	0	0
外接硬盘印刷电路板 Bridge PCB	X	0	0	0	0	0
电源 (如果提供) Power Supply (if provided)	X	0	0	0	0	0
接口电缆 (如果提供) Interface cable (if provided)	X	0	0	0	0	0
其他外壳组件 Other enclosure components	0	0	0	0	0	0

本表格依据 SJ/T 11364 的规定编制。  
This table is prepared in accordance with the provisions of SJ/T 11364-2014.  
0: 表示该有害物质在该部件所有均质材料中的含量均在 GB/T 26572 规定的限量要求以下。  
0: Indicates that the hazardous substance contained in all of the homogeneous materials for this part is below the limit requirement of GB/T26572.  
X: 表示该有害物质至少在该部件的某一均质材料中的含量超出 GB/T 26572 规定的限量要求。  
X: Indicates that the hazardous substance contained in at least one of the homogeneous materials used for this part is above the limit requirement of GB/T26572.

### Taiwan RoHS table

Taiwan RoHS refers to the Taiwan Bureau of Standards, Metrology and Inspection's (BSMI's) requirements in standard CNS 15663, Guidance to reduction of the restricted chemical substances in electrical and electronic equipment. Beginning on January 1, 2018, Seagate products must comply with the "Marking of presence" requirements in Section 5 of CNS 15663. This product is Taiwan RoHS compliant.

The following table meets the Section 5 "Marking of presence" requirements.  
台湾 RoHS 是指台灣標準局計量檢驗局 (BSMI) 對標準 CNS 15663 要求的減排電子電氣設備限用化學物質指引。從 2018 年 1 月 1 日起，Seagate 產品必須符合 CNS 15663 第 5 節「含有標示」要求。本產品符合台灣 RoHS。下表符合第 5 節「含有標示」要求。

單元 Unit	Product Name: Lyve Mobile Array, Model: SMMA001 限用物質及其化學符號 Restricted Substance and its chemical symbol					
	鉛 (Pb)	汞 (Hg)	鎘 (Cd)	六價鉻 (Cr <sup>VI</sup> )	多溴聯苯 (PBB)	多溴二苯醚 (PBDE)
硬盤驅動器/固態驅動器 HDD/SSD	—	0	0	0	0	0
外接硬盤印刷電路板 Bridge PCB	—	0	0	0	0	0
電源 (如果提供) Power Supply (if provided)	—	0	0	0	0	0
傳輸線材 (如果提供) Interface cable (if provided)	0	0	0	0	0	0
其他外殼組件 Other enclosure components	0	0	0	0	0	0

備考 1: "0" 係指該項限用物質之百分比含量未超出百分比含量基準值。  
Note 1: "0" indicates that the percentage content of the restricted substance does not exceed the percentage of reference value of presence.  
備考 2: "-" 係指該項限用物質為排除項目。  
Note 2: "-" indicates that the restricted substance corresponds to the exemption.

額定電壓/額定電流: 20VDC ± 13A 操作溫度: 5 ~ 40 °C  
本設備勿置於潮濕處。 當設備不用時，請將所有電源線拔除，避免電壓不穩而造成傷害。  
請將產品置於手冊規定的環境使用溫度，以避免過熱。 勿將任何液體灑入設備中，避免線路短路。  
連接至電源前，請先檢查電壓。 請勿自行調整或修理已通電的設備，以確保您的安全。

### FCC DECLARATION OF CONFORMANCE

This device complies with Part 15 of the FCC Rules. Operation is subject to the following two conditions: (1) this device may not cause harmful interference, and (2) this device must accept any interference received, including interference that may cause undesired operation.

### CLASS B

This equipment has been tested and found to comply with the limits for a Class B digital device, pursuant to Part 15 of the FCC Rules. These limits are designed to provide reasonable protection against harmful interference in residential installation. This equipment generates, uses, and can radiate radio frequency energy, and if not installed and used in accordance with the instructions, may cause harmful interference to radio communications.

この装置は、クラスB機器です。この装置は、住宅環境で使用することを目的としていますが、この装置がラジオやテレビジョン受信機に近接して使用されると、受信障害を引き起こすことがあります。取扱説明書に従って正しい取り扱いをして下さい。 VCCI-B

However, there is no guarantee that interference will not occur in a particular installation. If this equipment does cause harmful interference to radio or television reception, which can be determined by turning the equipment off and on, the user is encouraged to try to correct the interference by one or more of the following measures:

- Reorient or relocate the receiving antenna.
- Increase the separation between the equipment and receiver.
- Connect the equipment into an outlet on a circuit different from that to which the receiver is connected.
- Consult the dealer or an experienced radio/TV technician for help.

**CAUTION:** Any changes or modifications made to this equipment may void the user's authority to operate this equipment.



© 2023 Seagate Technology LLC. All rights reserved. Seagate, Seagate Technology and the Spiral logo are registered trademarks of Seagate Technology LLC in the United States and/or other countries. Lyve and USM are either trademarks or registered trademarks of Seagate Technology LLC or one of its affiliated companies in the United States and/or other countries. Thunderbolt and the Thunderbolt logo are trademarks of Intel Corporation in the U.S. and/or other countries. The PCIe word mark and/or PCIeExpress design mark are registered trademarks and/or service marks of PCI-SIG. All other trademarks or registered trademarks are the property of their respective owners. Complying with all applicable copyright laws is the responsibility of the user. Seagate reserves the right to change, without notice, product offerings or specifications.  
Seagate Technology LLC., 47488 Kato Road, Fremont, CA 94538 USA www.seagate.com  
Seagate Technology NL B.V., Tulpolevian 105, 1119 PA Schiphol-Rijk NL  
Seagate Technology NL B.V. (UK Branch), Jubilee House, Globe Park, 3rd Ave, Marlow SL7 1EY, UK  
Seagate Singapore International Headquarters Pte. Ltd., 90 Woodlands Avenue 7 Singapore 737911

PN: 100869100F 02/23



## LYVE™ Mobile Array



## QUICK START GUIDE