



Seagate® BarraCuda™ SATA SSD

Product Manual

240 GB	ZA240CV10002
256 GB	ZA256CV10002
480 GB	ZA480CV10002
512 GB	ZA512CV10002
960 GB	ZA960CV10002
1920 GB	ZA1920CV10002
3840 GB	ZA3840CV10002

© 2023, Seagate Technology LLC All rights reserved. Publication number: 204960300, Rev. A, March 2023

Seagate Technology reserves the right to make changes to the product(s) or information disclosed herein at any time without notice.

Seagate, Seagate Technology and the Spiral logo are registered trademarks of Seagate Technology LLC in the United States and/or other countries. BarraCuda and SeaTools are either trademarks or registered trademarks of Seagate Technology LLC or one of its affiliated companies in the United States and/or other countries. All other trademarks or registered trademarks are the property of their respective owners.

No part of this publication may be reproduced in any form without written permission of Seagate Technology LLC. Call 877-PUB-TEK1(877-782-8351) to request permission.

When referring to drive capacity, one gigabyte, or GB, equals one billion bytes and one terabyte, or TB, equals one trillion bytes. Your computer's operating system may use a different standard of measurement and report a lower capacity. In addition, some of the listed capacity is used for formatting and other functions, and thus will not be available for data storage. Actual quantities will vary based on various factors, including file size, file format, features and application software. Actual data rates may vary depending on operating environment and other factors. The export or re-export of hardware or software containing encryption may be regulated by the U.S. Department of Commerce, Bureau of Industry and Security (for more information, visit www.bis.doc.gov), and controlled for import and use outside of the U.S. Seagate reserves the right to change, without notice, product offerings or specifications.

Contents

Seagate Technology Support Services	5
1. Introduction	6
2. Specifications	8
2.1 Models and Capacity	8
2.2 Performance	8
2.3 Power Consumption	9
2.4 Environmental Conditions	9
2.5 Reliability/Endurance	10
3. Mechanical Information	11
3.1 Dimensions and Weight	11
4. Pin and Signal Descriptions	14
4.1 Signal Pin Definitions	14
4.2 Power Pin Definitions	14
5. Supported ATA Command List	15
5.1 ATA Feature Set	15
5.2 ATA Command Description	15
6. SMART Support	18
6.1 SMART ID	18
7. Feature Details	19
7.1 Flash Management	19
7.1.1 Error Correction Code (ECC)	19
7.1.2 Wear Leveling	19
7.1.3 Bad Block Management	19
7.1.4 TRIM	19
7.1.5 SMART	19
7.1.6 Over Provisioning	20
7.1.7 Firmware Upgrade	20
7.1.8 Low Power Management	20
7.1.8.1 DIPM	20
7.2 Advanced Device Security Features	20
7.2.1 Secure Erase	20
7.3 SSD Lifetime Management	20
7.3.1 Total Bytes Written (TBW)	20
7.3.2 Media Wear Indicator	21
7.3.3 Read Only Mode (End of Life)	21
7.4 Adaptive Approach to Performance Tuning	21
7.4.1 Throughput	21
7.4.2 Predict and Fetch	21
7.4.3 SLC Cache	21

8. Safety, Standards, and Compliance **22**
 8.1 Regulatory Model Numbers 22
 8.2 Reference Documents 22

Seagate Technology Support Services

For Internal SSD Support, visit: <https://www.seagate.com/support/products/>

For Firmware Download and Tools Download for Secure Erase, visit: <https://www.seagate.com/support/downloads/>

For information regarding online support and services, visit: <http://www.seagate.com/contacts/>

For information regarding Warranty Support, visit: <http://www.seagate.com/support/warranty-and-replacements/>

For information regarding data recovery services, visit:

<http://www.seagate.com/services-software/seagate-recovery-services/recover/>

For Seagate OEM and Distribution partner and Seagate reseller portal, visit: <http://www.seagate.com/partners>

1. Introduction

The Seagate® BarraCuda™ SATA SSD is a fast, dependable storage solution for everyday compute applications. The Seagate BarraCuda SATA SSD offers SATA interface, fully compatible with SATA 3.1 6.0Gbps.

Table 1 The BarraCuda SATA SSD Features

Feature	Description	
Capacity (User)	<ul style="list-style-type: none"> 240 GB, 256 GB, 480 GB, 512 GB, 960 GB, 1920 GB, 3840 GB 	
Certifications, Eco-Compliance	<ul style="list-style-type: none"> CE, UL, FCC, BSMI, KCC, Microsoft WHQL, VCCI, CB RoHS 	
Dimensions	<ul style="list-style-type: none"> (69.85±0.25) x (100±0.25) x (Max. 7) mm 	SSD outer case can support suitable Z-height for various host situations.
Endurance	Total Bytes Written (TBW) <ul style="list-style-type: none"> 240 GB: 80 TB 256 GB: 75 TB 480 GB: 170 TB 512 GB: 160 TB 960 GB: 300 TB 1920 GB: 600 TB 3840 GB: 1200 TB 	Endurance rating valid for SSD Life Remaining > 1% (SMART E7h>1). See Section 2.5, Reliability/Endurance .
Form Factor	<ul style="list-style-type: none"> 2.5-inch Standard SSD 	
Interface Compliance	<ul style="list-style-type: none"> Fully compliant with ATA-8/ACS-4 Standard Compliant with SATA Revision 3.1 Supported protocol AHCI and ASC2 command set Compatible with SATA 1.5 Gbps, 3 Gbps, and 6Gbps interfaces PIO, DMA, UDMA (up to 6 modes, dependent on host) supported Native Command Queuing (NCQ): up to 32 commands Data Set Management Command Trim support 	
NAND	<ul style="list-style-type: none"> 3D 	
Operating Systems	<ul style="list-style-type: none"> Windows® 11 (64 bit), and Windows 10 (64 bit) Ubuntu 16.10 	
Performance Sequential	<ul style="list-style-type: none"> Read: Up to 540MB/s Write: Up to 510MB/s 	Actual performance might vary depending on the capacity, use conditions and environment. See Section 2.2, Performance .
Power Consumption	<ul style="list-style-type: none"> Active mode: < 1400 mW Idle mode: < 250 mW 	Based on 250 GB SSD. Results vary with capacity and mode. See Section 2.3, Power Consumption .
Power Loss Data Protection	<ul style="list-style-type: none"> To protect your data, you must send a Standby Immediate command (0xE1h) before you remove power. The BarraCuda SATA SSD does not provide data protection for a sudden power loss. 	
Power Management	<ul style="list-style-type: none"> 2.5 inch: 5 V SATA Supply Host-initiated power management (HIPM) Device-initiated power management (DIPM) 	
Reliability	<ul style="list-style-type: none"> End-to-end data path protection MTBF: 1.8 million hours UBER: 1 error in 10¹⁵ bits read 	

Table 1 The BarraCuda SATA SSD Features (continued)

Feature	Description	
Shock and Vibration	Shock <ul style="list-style-type: none"> ■ Non-Operating: 1,500 G, at 0.5 ms 	See Section 2.4, Environmental Conditions.
	Vibration <ul style="list-style-type: none"> ■ Non-Operating: 1.52 G_{RMS}, (20 to 80 Hz, Frequency) 	
Temperature Range (Operating)	<ul style="list-style-type: none"> ■ 0°C to 70°C ■ Temperature Sensor (SMART Attribute ID C2h) 	
Voltage	<ul style="list-style-type: none"> ■ 5V±5% 	
Warranty	Three years, or when the device reaches Host TBW, whichever happens first. Endurance rating valid for SSD Life Remaining > 1% (SMART E7h>1).	
Weight	<ul style="list-style-type: none"> ■ 50 g, 1.76 Oz ±5% 	

2. Specifications

2.1 Models and Capacity

Table 2 Models and Capacity

User Capacity	Model Names
240 GB	ZA240CV10002
256 GB	ZA256CV10002
480 GB	ZA480CV10002
512 GB	ZA256CV10002
960 GB	ZA960CV10002
1920 GB	ZA1920CV10002
3840 GB	ZA3840CV10002

NOTE About capacity:

- Sector Size: 512 Bytes
- User-addressable LBA count = ((97696368) + (1953504 x (Desired Capacity in Gb-50.0))) From International Disk Drive Equipment and Materials Association (IDEMA) (*LBA1-03_standard.doc*)

2.2 Performance

Table 3 Sequential Read and Write Performance

Parameter	240 GB	256 GB	480 GB	512 GB	960 GB	1920 GB	3840 GB
Sequential Read MB/s	540	540	540	540	540	540	540
Sequential Write MB/s	490	490	500	500	510	510	510

NOTE About performance:

- Fresh out of box (FOB) performance obtained on newly formatted drive. Performance may vary based on the SSD's firmware version, system hardware, and configuration.
- Performance is based on CrystalDiskMark v.6.0.0 x64 on with SATA 6Gb/s host.

2.3 Power Consumption

Table 4 Power Consumption

	240 GB	256 GB	480 GB	512 GB	960 GB	1920 GB	3840 GB
Read (mW)	1200	1200	1250	1250	1300	1350	1400
Write (mW)	1200	1200	1250	1250	1300	1350	1400
Partial (mW)	60	60	60	60	60	60	60
Slumber (mW)	20	20	20	20	20	20	20
Idle (mW)	250	250	250	250	250	250	250

NOTE

About power consumption:

- The average value of power consumption is based on 100% conversion efficiency.
- The measured power voltage is 5 V.
- Measured under ambient temperature.
- Sequential Read/Write is measured while testing 1GB sequential R/W five times by CrystalDiskMark.
- Power Consumption varies with flash configuration and platform.

2.4 Environmental Conditions

Table 5 Temperature, Humidity, Shock

Specification	Value
Temperature	
Operating (case temperature at specific airflow)	0°C to 70°C
Non-operating	-40°C to 85°C
Humidity	
Operating	90%
Non-operating (storage)	93%
Shock	
Non-operating	1,500 G, duration 0.5 ms
Vibration	
Non-operating	1.52 G _{RMS} , (20Hz to 80Hz, Frequency)

NOTE

Temperature is measured without condensation. Operating mode temperature is measured by temperature sensor, SMART Attribute C2h.

NOTE

Shock and vibration results assume the SSD is mounted securely with the input vibration applied to the SSD mounting. These specifications do not cover connection issues that may result from testing at this level. The measured specification is in root mean square (RMS) form.

- **Non-operating Shock.** The limits of non-operating shock applies to all conditions of handling and transportation. This includes both isolated SSD and integrated SSDs. Shock may be applied in the X, Y, or Z-axis.
- **Non-Operating Vibration.** The limits of non-operating vibration shall apply to all conditions of handling and transportation. This includes both isolated SSD and integrated SSDs. Vibration may be applied in the X, Y, or Z-axis.

2.5 Reliability/Endurance

Table 6 Reliability/Endurance

Specification	Value
Mean time between failures (MTBF)	1.8 million hours
Bit Error Rate	1 error in 10^{16} bits read
Endurance	TBW <ul style="list-style-type: none"> ■ 240 GB: 80 TB ■ 256 GB: 75 TB ■ 480 GB: 170 TB ■ 512 GB: 160 TB ■ 960 GB: 300 TB ■ 1920 GB: 600 TB ■ 3840 GB: 1200 TB

NOTE

About endurance:

- The SSD achieves the specified MTBF in an operational environment that complies with the operational temperature range specified in this manual. Operating temperatures are measured by temperature sensor, SMART Attribute ID C2h.
- Endurance rating valid for SSD Life Remaining > 1% (SMART E7h>1).
- Endurance is characterized while running Client JESD219A workload (per JESD218A specification).

3. Mechanical Information

3.1 Dimensions and Weight

Weight: 50 g, 1.76 Oz +/- 5%

Height: Maximum, 7 mm+0.10/-0.30

Width: 69.85 mm±0.25 mm

Length: 100.10 mm±0.25 mm

Figure 1 BarraCuda SATA SSD Top View

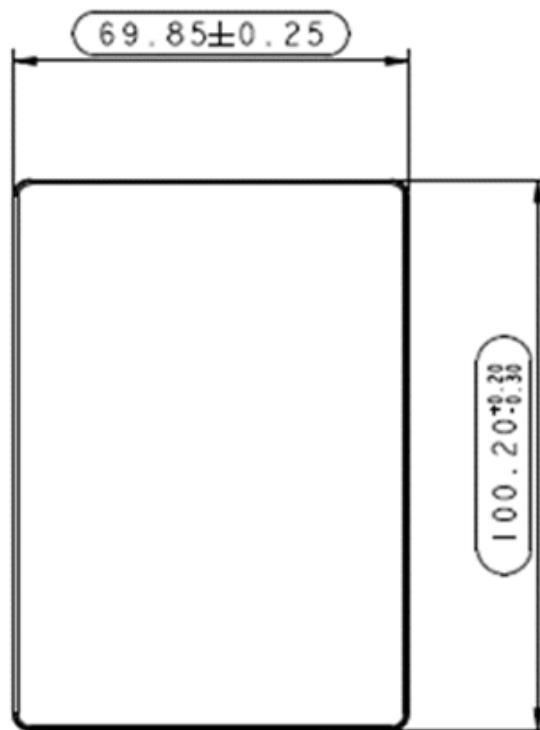

Figure 2 BarraCuda SATA SSD Bottom View

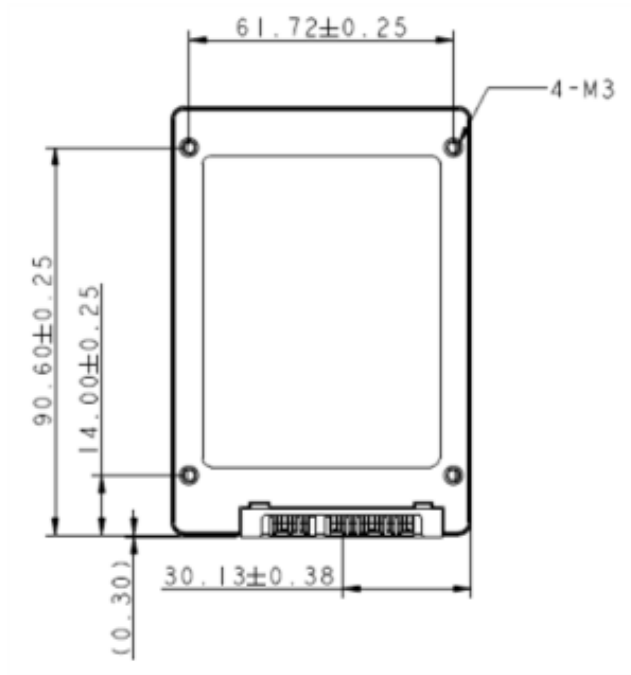

Figure 3 BarraCuda SATA SSD Side View

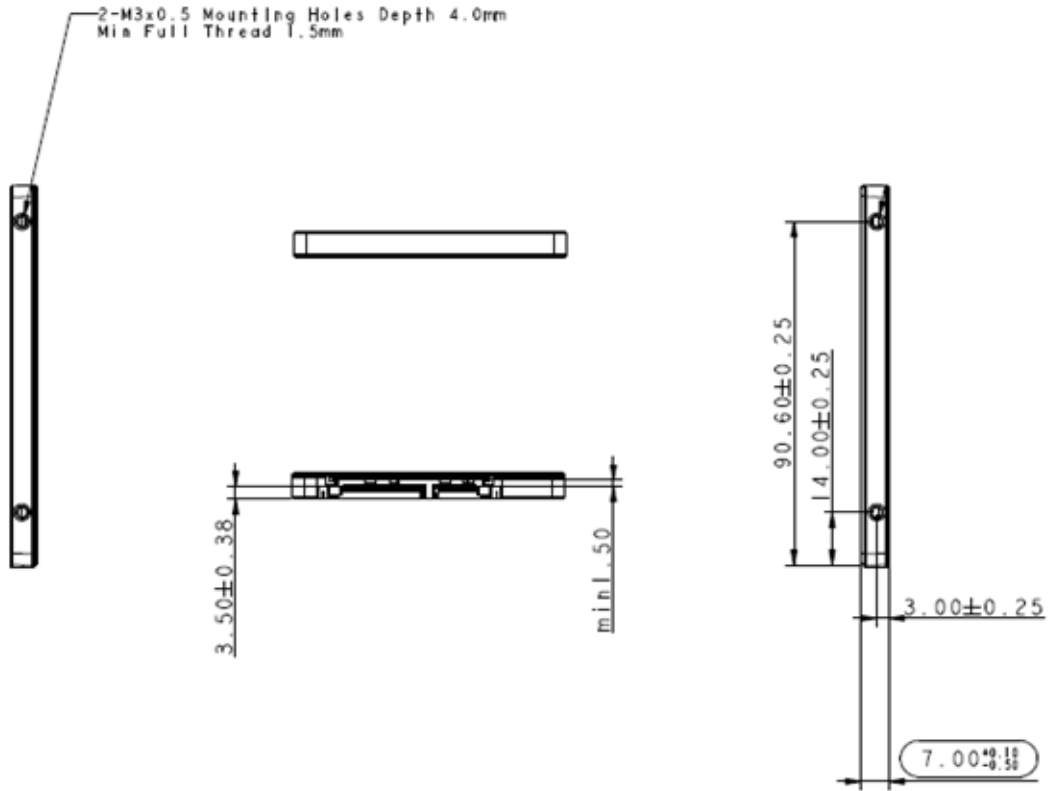

Table 7 BarraCuda SATA SSD Torque

Specification	Force
Screw Torque (Nominal / Max)	4kgf-cm/7kgf-cms

NOTE Do not over-tighten or force the screws

4. Pin and Signal Descriptions

4.1 Signal Pin Definitions

Table 8 Serial ATA Connector Pin Signal Definitions

Pin	Name	Definition
S1	Ground	Ground
S2	A+	Differential signal pair A+ and A-
S3	A-	
S4	Ground	Ground
S5	B-	Differential signal pair B- and B+
S6	B+	
S7	Ground	Ground

NOTE Key and spacing separate the signal and power segments.

4.2 Power Pin Definitions

Table 9 Power Pin Definitions

Pin	Function	Definition
P1	not used	Not Used (3.3 V)
P2	V33	Not Used (3.3 V)
P3	DEVSLP	SATA PHY Power Control
P4	GND	Ground
P5	GND	Ground
P6	GND	Ground
P7	V5	5 V Power, Precharge
P8	V5	5 V Power
P9	V5	5 V Power
P10	GND	Ground
P11	Reserved	Reserved
P12	GND	Ground
P13	not used	Not Used (12 V pre-charge)
P14	V12	Not Used (12 V)
P15	V12	Not Used (12 V)

NOTE About Power Pin Signal Definitions:

- Key and spacing separate the signal and power segments.
- Uses 5 V power only; 3.3 V (P1-P2) and 12 V (P13-P15) power are not used.

5. Supported ATA Command List

The BarraCuda SATA SSD complies with ATA-8/ACS-4. All mandatory and many optional commands and features are supported.

5.1 ATA Feature Set

The following table summarizes the ATA feature set and commands that the BarraCuda SATA SSD supports.

Table 10 ATA Feature Set

Feature	Supported
48-Bit Address feature set	Yes
General feature set	Yes
Native Command Queuing (NCQ) feature set	Yes
Power Management feature set	Yes
Security feature set	Yes
SMART feature set	Yes

5.2 ATA Command Description

The following table shows the ATA commands supported.

Table 11 ATA Command Description

Op Code	Description	Op Code	Description
00h	NOP	C9h	Read DMA without Retry
06h	Data Set Management	CAh	Write DMA
10h-1Fh	Recalibrate	CBh	Write DMA without Retry
20h	Read Sectors	CEh	Write Multiple FUA EXT
21h	Read Sectors without Retry	E0h	Standby Immediate
24h	Read Sectors EXT	E1h	Idle Immediate
25h	Read DMA EXT	E2h	Standby
27h	Read Native Max Address EXT	E3h	Idle
29h	Read Multiple EXT	E4h	Read Buffer
2Fh	Read Log EXT	E5h	Check Power Mode
30h	Write Sectors	E6h	Sleep
31h	Write Sectors without Retry	E7h	Flush Cache
34h	Write Sectors EXT	E8h	Write Buffer
35h	Write DMA EXT	E9h	READ BUFFER DMA
37h	Set Native Max Address EXT	EAh	Flush Cache EXT

Table 11 ATA Command Description (continued)

38h		CFA Write Sectors Without Erase (Cfast Only)	EBh		Write Buffer DMA
39h		Write Multiple EXT	ECh		Identify Device
3Dh		Write DMA FUA EXT	EFh		Set Features
3Fh		Write Long EXT	EFh	02h	Enable volatile write cache
40h		Read Verify Sectors	EFh	03h	Set transfer mode
41h		Read Verify Sectors without Retry	EFh	05h	Enable the APM feature set
42h		Read Verify Sectors EXT	EFh	10h	Enable use of SATA features et
44h		Zero EXT	EFh	10h 02h	Enable DMA Setup FIS Auto-Activate optimization
45h		Write Uncorrectable EXT	EFh	10h 03h	Enable Device-initiated interface power state (DIPM) transitions
47h		Read Log DMA EXT	EFh	10h 06h	Enable Software Settings Preservation (SSP)
57h		Write Log DMA EXT	EFh	10h 07h	Enable Device Automatic Partial to Slumber transitions
60h		Read FPDMA Queued	EFh	10h 09h	Enable Device Sleep
61h		Write FPDMA Queued	EFh	55h	Disable read look-ahead
70h-7Fh		Seek	EFh	66h	Disable reverting to power-on defaults
90h		Execute Device Diagnostic	EFh	82h	Disable volatile write cache
91h		Initialize Device Parameters	EFh	85h	Disable the APM feature set
92h		Download Microcode	EFh	90h	Disable use of SATA feature set
93h		Download Microcode DMA	EFh	90h 02h	Disable DMA Setup FIS Auto-Activate optimization
B0h		SMART	EFh	90h 03h	Disable Device-initiated interface power state (DIPM) transitions
B0h	D0h	SMART READ DATA	EFh	90h 06h	Disable Software Settings Preservation (SSP)
B0h	D1h	SMART READ ATTRIBUTE THRESHOLDS	EFh	90h 07h	Disable Device Automatic Partial to Slumber transitions
B0h	D2h	SMART ENABLE/DISABLE ATTRIBUTE AUTOSAVE	EFh	90h 09h	Disable Device Sleep
B0h	D3h	SMART SAVE ATTRIBUTE VALUES	EFh	AAh	Enable read look-ahead
B0h	D4h	SMART EXECUTE OFF-LINE IMMEDIATE	EFh	CCh	Enable reverting to power-on defaults
B0h	D5h	SMART READ LOG	F1h		Security Set Password
B0h	D6h	SMART WRITE LOG	F2h		Security Unlock
B0h	D8h	SMART ENABLE OPERATIONS	F3h		Security Erase Prepare
B0h	D9h	SMART DISABLE OPERATIONS	F4h		Security Erase Unit
B0h	DAh	SMART RETURN STATUS	F5h		Security Freeze Lock
B0h	DBh	SMART ENABLE/DISABLE AUTOMATIC OFF-LINE	F6h		Security Disable Password

Table 11 ATA Command Description (continued)

B1h	Device Configuration	F8h		Read Native Max Address
B4h	Sanitize	F9h		Set Max Address
C4h	Read Multiple	F9h	01h	SET MAX SET PASSWORD
C5h	Write Multiple	F9h	02h	SET MAXLOCK
C6h	Set Multiple Mode	F9h	03h	SET MAX UNLOCK
C8h	Read DMA	F9h	04h	SET MAX FREEZE LOCK

6. SMART Support

The BarraCuda SATA SSD supports the SMART command set.

6.1 SMART ID

The following table lists SMART IDs and Descriptions.

Table 12 SMART Attribute IDs and Descriptions

0	1	2	3	4	5	6	7	8	9	10	11	12
ID	flag	flag	value	worst	DATA						Reserved	Threshold
01h	0Bh	00h	64h	64h	Number of ECC Error						0	32h
09h	12h	00h	64h	64h	Power-on Hours Count						0	00h
0Ch	12h	00h	64h	64h	Power On/Off Cycles Count						0	00h
A8h	12h	00h	64h	64h	SATA PHY Error Count						0	00h
AAh	03h	00h	100-Max BadBlock Percent	100-Max BadBlock Percent	Early Bad Block Count	0		Later Bad Block Count		0	0Ah	
ADh	12h	00h	64h	64h	Max erase count	Avg erase count		0		0	00h	
C0h	12h	00h	64h	64h	Unexpected Power Loss Count						0	00h
DAh	0Bh	00h	64h	64h	CRC Error Count						0	32h
E7h	13h	00h	64h	64h	SSD Life Left						0	00h
E9h	32h	00h	64h	64h	Nand Write (GiB)						0	00h
F1h	12h	00h	64h	64h	Host Write (GiB)						0	00h

7. Feature Details

7.1 Flash Management

7.1.1 Error Correction Code (ECC)

Flash memory cells deteriorate with use, which might generate random bit errors in the stored data. The BarraCuda SATA SSD applies the LDPC (Low Density Parity Check) of ECC algorithm, which detects and corrects errors that occur during read process, ensures data is read correctly, and protects data from corruption.

7.1.2 Wear Leveling

NAND flash devices can undergo only a limited number of program/erase cycles. Commonly, areas of the flash media are not used evenly. If some areas are updated more frequently than others, this reduces the lifetime of the device. Wear Leveling extends the life of the NAND Flash by evenly distributing write and erase cycles across the media.

Seagate's advanced Wear Leveling algorithm spreads the flash usage throughout the whole flash media area. Implementing dynamic and static Wear Leveling algorithms improves the life expectancy of the NAND flash.

7.1.3 Bad Block Management

Bad blocks do not function properly and they can contain more invalid bits. This can make stored data unstable and bad block reliability is not guaranteed. Blocks identified and marked as bad by the manufacturer are called "Early Bad Blocks". Bad blocks that develop during the lifespan of the Flash are called "Later Bad Blocks". Seagate's bad block management algorithm detects the factory-produced bad blocks and manages bad blocks that appear with use. This practice prevents data from being stored in bad blocks and improves data reliability.

7.1.4 TRIM

The TRIM feature improves the read/write performance and speed of SSDs. SSDs cannot overwrite existing data, so the available space becomes smaller with each data block use. The TRIM command tells the SSD (through the operating system) which data blocks can be removed permanently because they are no longer in use. The SSD erases these unused data blocks.

7.1.5 SMART

SMART, stands for Self-Monitoring, Analysis, and Reporting Technology, is an open standard that allows an SSD to automatically detect its health and report potential failures. When SMART records a failure, users can replace the drive to prevent unexpected outage or data loss. SMART can also inform users of impending failures while there is still time to copy data to another device.

7.1.6 Over Provisioning

Over Provisioning (OP) preserves an additional area beyond user capacity in a SSD, which is not visible to users and cannot be used by them. With Over Provisioning, the performance and IOPS (Input/Output Operations per Second) are improved by providing the controller additional space to manage P/E cycles, which enhances the reliability and endurance as well. Moreover, the write amplification of the SSD becomes lower when the controller writes data to the flash.

7.1.7 Firmware Upgrade

Firmware is a set of instructions on how the device communicates with the host. Firmware is upgraded when new features are added, compatibility issues are fixed, or read/write performance gets improved.

7.1.8 Low Power Management

7.1.8.1 DIPM

SATA interfaces contain two low power management states for power saving: Partial and Slumber modes. For Partial mode, the device has to resume to full operation within 10 microseconds, whereas the device will spend 10 milliseconds to become fully operational in the Slumber mode. SATA interfaces allow low power modes to be initiated by Host (HIPM, Host Initiated Power Management) or Device (DIPM, Device Initiated Power Management). As for HIPM, Partial or Slumber mode can be invoked directly by the software. For DIPM, the device will send requests to enter Partial or Slumber mode.

7.2 Advanced Device Security Features

7.2.1 Secure Erase

Secure Erase is a standard ATA command and it writes all of "0xFF" to fully wipe all the data on hard drives and SSDs. When this command is issued, the SSD controller erases its storage blocks and returns to its factory default settings.

7.3 SSD Lifetime Management

7.3.1 Total Bytes Written (TBW)

TBW measures the lifespan of the SSD. This measurement represents the amount of data written to the device. To calculate the TBW of a SSD, use the following equation:

$$TBW = [(NAND\ Endurance) \times (SSD\ Capacity)] / [WAF]$$

NAND Endurance: NAND endurance refers to the P/E (Program/Erase) cycle of a NAND flash.

SSD Capacity: The SSD capacity is the specific capacity in total of a SSD.

WAF: Write Amplification Factor (WAF) is a numerical value representing the ratio between the amount of data that a SSD controller needs to write and the amount of data that the host's flash controller writes. A better WAF, which is near 1, guarantees better endurance and lower frequency of data written to flash memory.

TBW in this document is based on JEDEC 218/219 workload.

7.3.2 Media Wear Indicator

Actual life indicator reported by SMART Attribute 231 (E7h), Percentage Used, recommends user to replace drive when reaching 100%.

7.3.3 Read Only Mode (End of Life)

When the SSD is aged by program/erase cycles, media wear-out may cause increasing numbers of bad blocks. When the number of usable good blocks falls outside a defined usable range, the drive notifies the host through AER event and Critical Warning to enter Read Only Mode to prevent further data corruption. When this happens, the user should replace the SSD with another one immediately.

7.4 Adaptive Approach to Performance Tuning

7.4.1 Throughput

Based on the available space of the disk, the BarraCuda SATA SSD regulates the read/write speed and manages the performance of throughput. When there is a lot of space, the firmware continuously performs read/write actions. There is no need yet to implement garbage collection to allocate and release memory to accelerate the read/write processing and improve performance. When there is less available space, the SSD slows down the read/write processing and implements garbage collection to release memory.

7.4.2 Predict and Fetch

When the Host tries to read data from the SSD, the SSD performs only one read action after receiving one command. However, the BarraCuda SATA SSD applies Predict and Fetch to improve the read speed. When the host issues sequential read commands to the SSD, the SSD automatically expects that the following is also read commands. Therefore, before receiving the next command, flash has already prepared the data. This accelerates data processing time, and the host needs to wait less time to receive data.

7.4.3 SLC Cache

The BarraCuda SATA SSD firmware design adopts static and dynamic SLC caching to deliver optimized performance, endurance and user experience. The dynamic SLC cache size is set at up to 1/4 of the SSD's free user capacity.

8. Safety, Standards, and Compliance

Each Hard Drive and Solid State Drive ("device") has a product label that includes certifications that apply to that specific drive. The following information provides an overview of requirements that may apply to the drive.

NOTE

The most up to date information on Safety, Standards, and Compliance for this product is available in the Seagate HDD and SSD Regulatory Compliance and Safety document. You can find this document here:

<https://www.seagate.com/files/www-content/forms/compliance/regulatory-compliance-and-safety-100838899-A.pdf>

8.1 Regulatory Model Numbers

The following regulatory model number represents all features and configurations in the series:

- STA038

8.2 Reference Documents

In case of conflict between this document and any reference document, this document takes precedence.

Table 13 Reference Documents

Title
SATA-IO Commands for ATA-8
<i>Solid-State Drive (SSD) Requirements and Endurance Test Method(JESD218A)</i>
Serial ATA Revision 3.1
IDEMA (LBA1-03_standard.doc)
SOLID-STATE DRIVE (SSD) Endurance Workload(JESD219A)
ATA/ATAPI Command Set -2 (ACS-4) Revision 5



Seagate Technology LLC

AMERICAS Seagate Technology LLC 47488 Kato Road, Fremont, California 94538, United States, 510-661-1000

ASIA/PACIFIC Seagate Singapore International Headquarters Pte. Ltd. 7000 Ang Mo Kio Avenue 5, Singapore 569877, 65-6485-3888

EUROPE, MIDDLE EAST AND AFRICA Seagate Technology Netherlands BV, Tupolevlaan, 105, 119 PA Schiphol-Rijk, the Netherlands

Publication Number: 204960300, Rev. A

March 2023