

A decorative graphic on the left side of the page. It features a large dashed circle at the top left, a solid blue circle below it, and several overlapping curved lines in light blue and grey that sweep across the page. A small solid blue circle is positioned above the top dashed line.

---

Product Manual

# Momentum 7200.1 PATA

---

**ST910021A**

**ST980825A**

**ST96023A**

**ST94015A**

100320518  
Rev. C  
August 2007

©2004-2007, Seagate Technology LLC All rights reserved.

Publication number: 100320518, Rev. C

August 2007

Seagate, Seagate Technology and the Wave logo are registered trademarks of Seagate Technology LLC in the United States and/or other countries. Momentus, Seagate-SeaBOARD, SeaFONE, SeaTDD, and SeaTools are either trademarks or registered trademarks of Seagate Technology LLC or one of its affiliated companies in the United States and/or other countries. All other trademarks or registered trademarks are the property of their respective owners.

One gigabyte, or GB, equals one billion bytes and one terabyte, or TB, equals one trillion bytes when referring to hard drive capacity. Accessible capacity may vary depending on operating environment and formatting. Quantitative usage examples for various applications are for illustrative purposes. Actual quantities will vary based on various factors, including file size, file format, features and application software. Seagate reserves the right to change, without notice, product offerings or specifications.

# Contents

<b>1.0</b>	<b>Introduction</b>	<b>1</b>
<b>2.0</b>	<b>Drive specifications</b>	<b>3</b>
2.1	Specification summary	3
2.2	Formatted capacity	5
2.3	Default logical geometry	5
2.4	Physical organization	5
2.5	Recording and interface technology	6
2.6	Physical characteristics	6
2.7	Seek time	7
2.8	Time to ready	7
2.9	Power specifications	8
2.9.1	Power consumption	8
2.9.2	Conducted noise	9
2.9.3	Voltage tolerance	9
2.9.4	Power-management modes	10
2.10	Environmental specifications	11
2.10.1	Ambient temperature	11
2.10.2	Temperature gradient	11
2.10.3	Humidity	11
2.10.4	Altitude	11
2.10.5	Shock	12
2.10.6	Vibration	12
2.11	Acoustics	13
2.12	Electromagnetic immunity	13
2.13	Reliability	14
2.14	Agency certification	14
2.14.1	Safety certification	14
2.14.2	Electromagnetic compatibility	14
2.14.3	FCC verification	15
2.15	Environmental protection	16
2.15.1	European Union Restriction of Hazardous Substances (RoHS)	16
2.15.2	China Restriction of Hazardous Substances (RoHS) Directive	16
<b>3.0</b>	<b>Configuring and mounting the drive</b>	<b>19</b>
3.1	Handling and static discharge precautions	19
3.2	Jumper settings	19
3.2.1	Master/slave configuration	19
3.2.2	Cable-select option	20
3.3	Drive mounting	20
<b>4.0</b>	<b>ATA interface</b>	<b>21</b>
4.1	ATA interface signals and connector pins	21
4.1.1	Supported ATA commands	22
4.1.2	Identify Device command	25
4.1.3	Set Features command	28
<b>5.0</b>	<b>Seagate Technology support services</b>	<b>29</b>



## List of Figures

Figure 1.	Momentum 7200.1 PATA disc drive . . . . .	1
Figure 2.	Typical 5V startup and operating current profile . . . . .	9
Figure 3.	Jumper settings . . . . .	19
Figure 4.	Mounting dimensions—top, side and end view . . . . .	20



## 1.0 Introduction

---

This manual describes the functional, mechanical and interface specifications for the following Seagate® Momentus 7200.1 PATA drives:

- ST910021A
- ST980825A
- ST96023A
- ST94015A

These drives provide the following key features:

- 7,200-RPM spindle speed and 8-Mbyte buffer combine for superior performance.
- Quiet operation. Fluid Dynamic Bearing (FDB) motor.
- High instantaneous (burst) data transfer rates (up to 100 Mbytes per second) using Ultra DMA mode 5.
- Tunneling Magnetoresistive (TMR) recording heads.
- State-of-the-art cache and on-the-fly error-correction algorithms.
- Full-track multiple-sector transfer capability without local processor intervention.
- 800 Gs nonoperating shock.
- 250 Gs operating shock.
- SeaTools diagnostic software performs a drive self-test that eliminates unnecessary drive returns.
- Support for S.M.A.R.T. drive monitoring and reporting.
- Support for Read Multiple and Write Multiple commands.
- Support for autodetection of master/slave drives that use cable select (CSEL).

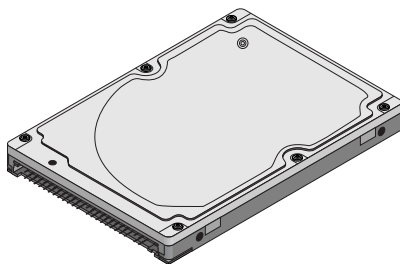

**Figure 1. Momentus 7200.1 PATA disc drive**





## 2.0 Drive specifications

---

Unless otherwise noted, all specifications are measured under ambient conditions, at 25°C, and nominal power. For convenience, the phrases *the drive* and *this drive* are used throughout this manual to indicate ST910021A, ST980825A, ST96023A and ST94015A model drives.

### 2.1 Specification summary

The specifications listed in this table are for quick reference. For details on specification measurement or definition, see the appropriate section of this manual.

**Table 1: Specifications**

Drive specification	ST910021A	ST980825A	ST96023A	ST94015A
Formatted Gbytes (512 bytes/sector)	100	80	60	40
Guaranteed sectors	195,371,568	156,301,488	117,210,240	78,140,160
Bytes per sector	512			
Physical read/write heads	4	4	3	2
Discs	2	2	2	1
Cache (Mbytes)	8			
Recording density, BPI (bits/inch max)	700,000			
Track density, TPI (tracks/inch max)	114,000			
Areal density (Bbits/inch <sup>2</sup> max)	81			
Spindle speed (RPM)	7,200			
Internal data transfer rate OD (Mbits/sec max)	539			
Sustained data transfer rate OD (Mbytes/sec)	45.8			
I/O data-transfer rate (Mbytes/sec max)	100			
ATA data-transfer modes supported	PIO modes 0–4 Multiword DMA modes 0–2 Ultra DMA modes 0–5			
Height	9.5 +/-0.2 mm (0.374 +/-0.0078 inches)			
Width	69.85 +/-0.25 mm (2.75 +/-0.0098 inches)			
Length	100.2 +/-0.25 mm (3.945 +/-0.0098 inches)			
Weight (typical)	115 grams (0.254 lb)			
Average latency (msec)	4.2			
Power-on to ready (typical)	4 seconds			
Standby to ready (typical)	3 seconds			
Startup current 5V (peak)	1.1 amps			
Track-to-track seek time (msec typical)	1.5 (read), 2.0 (write)			
Average seek, read (msec typical)	10.5			
Average seek, write (msec typical)	12.5			
Full-stroke seek (msec)	22 (typical); 28 (max)			

**Table 1: Specifications**

Drive specification	ST910021A	ST980825A	ST96023A	ST94015A
Seek power (typical)	2.6 watts			
Read/write power (typical)	2.2 watts			
Idle mode (typical)	1.3 watts			
Standby mode	0.26 watts (typical)**			
Sleep mode	0.26 watts (typical)**			
Voltage tolerance (including noise)	+5V ± 5% / -8% startup			
Ambient temperature	5° to 55°C (operating) -40° to 70°C (nonoperating)			
Temperature gradient (°C per hour max)	20°C (operating) 30°C (nonoperating)			
Relative humidity (noncondensing)	5% to 90% (operating) 5% to 95% (nonoperating)			
Relative humidity gradient	30% per hour max			
Wet bulb temperature (°C max)	30°C (operating) 40°C (nonoperating)			
Altitude, operating	-304.8 m to 3,048 m (-1000 ft to 10,000+ ft)			
Altitude, nonoperating (below mean sea level, max)	-304.8 m to 12,192 m (-1,000 ft to 40,000+ ft)			
Shock, operating (Gs max at 2 msec)	250			
Shock, nonoperating (Gs max at 2 msec)	800			
Shock, nonoperating (Gs max at 1 msec)	900			
Shock, nonoperating (Gs max at 0.5 msec)	400			
Vibration, operating (max displacement may apply below 10 hz)	1.0 Gs (0 to peak, 5–500 Hz)			
Vibration, nonoperating (max displacement may apply below 22 hz)	5.0 Gs (0 to peak, 5–500 Hz)			
Drive acoustics, sound power (bels)				
Idle*	2.5 (typical) 2.8 (max)			
Seek	2.9 (typical) 3.1 (max)			
Nonrecoverable read errors	1 per 10 <sup>14</sup> bits read			
Annualized Failure Rate (AFR)	0.73%			
Load/Unload (U/UL) cycles				
40°C, 50% relative humidity	600,000 software-controlled power on/off cycles 20,000 hard power on/off cycles			
32°C, 80% relative humidity	100,000 software-controlled power on/off cycles			
5°C, 80% relative humidity	20,000 hard power on/off cycles			
5°C, 10% relative humidity				
55°C, 16% relative humidity				
Service life	5 Years			
Warranty	5 Years on distribution units. To determine the warranty for a specific drive, use a web browser to access the following web page: <a href="http://www.seagate.com/support/service/">www.seagate.com/support/service/</a> From this page, click on the "Verify Your Warranty" link. You will be asked to provide the drive serial number, model number (or part number) and country of purchase. The system will display the warranty information for your drive.			

\*During periods of drive idle, some offline activity may occur according to the S.M.A.R.T. specification, which may increase acoustic and power to operational levels.

\*\*Typical notebooks will pull power to the drive when entering S3 and S4; while in the S3 and S4 states, drive sleep and drive standby modes will not contribute to battery power consumption.

## 2.2 Formatted capacity

Model	Formatted capacity	Guaranteed sectors	Bytes per sector
ST910021A	100 Gbytes	195,371,568	512
ST980825A	80 Gbytes	156,301,488	512
ST96023A	60 Gbytes	117,210,240	512
ST94015A	40 Gbytes	78,140,160	512

## 2.3 Default logical geometry

Cylinders	Read/write heads	Sectors per track
16,383	16	63

### LBA mode

When addressing these drives in LBA mode, all blocks (sectors) are consecutively numbered from 0 to  $n-1$ , where  $n$  is the number of guaranteed sectors as defined above.

## 2.4 Physical organization

Model	Read/write heads	Number of discs
ST910021A	4	2
ST980825A	4	2
ST96023A	3	2
ST94015A	2	1

## 2.5 Recording and interface technology

Technology	Specification
Interface	Parallel ATA
Recording method	RLL 0,11
Recording density BPI (bits/inch max)	700,000
Track density TPI (tracks/inch max)	114,000
Areal density (Gbits/inch <sup>2</sup> max)	81
Spindle speed (RPM) ( $\pm 0.2\%$ )	7,200
Internal data-transfer rate OD (Mbits/sec max)	539
Sustained data transfer rate OD (Mbytes/sec max)	45.8
I/O data-transfer rate (Mbytes/sec max)	100 (Ultra DMA mode 5)
Interleave	1:1
Cache buffer	8 Mbytes (8,192 kbytes)

## 2.6 Physical characteristics

Height	(mm) (inches)	9.5 +/-0.2 0.374 +/-0.0078
Width	(mm) (inches)	69.85 +/-0.25 2.75 +/-0.0098
Length	(mm) (inches)	100.2 +/-0.25 3.945 +/-0.0098
Typical weight	(grams) (pounds)	115 0.254

## 2.7 Seek time

Seek measurements are taken with nominal power at 25°C ambient temperature. All times are measured using drive diagnostics. The specifications below are defined as follows:

- Track-to-track seek time is an average of all possible single-track seeks in both directions.
- Average seek time is a true statistical random average of at least 5,000 measurements of seeks between random tracks, less overhead.

*Typical seek times (msec)	Read	Write
Track-to-track	1.5	2.0
Average	10.5	12.5
Full-stroke	22.0	24.0
Average latency	4.2	

\*Measured in performance mode

**Note.** These drives are designed to consistently meet the seek times represented in this manual. Physical seeks, regardless of mode (such as track-to-track and average), are expected to meet or exceed the noted values. However, due to the manner in which these drives are formatted, benchmark tests that include command overhead or measure logical seeks may produce results that vary from these specifications.

## 2.8 Time to ready

Time to ready	Typical	Max
Power-on to Ready (sec)	4	8
Standby to Ready (sec)	3	8

## 2.9 Power specifications

The drive receives DC power (+5V) through the interface connector.

### 2.9.1 Power consumption

Power requirements for the drives are listed in the Table 2 on page 8. Typical power measurements are based on an average of drives tested, under nominal conditions, using 5.0V input voltage at 25°C ambient temperature.

- **Spinup power**

Spinup power is measured from the time of power-on to the time that the drive spindle reaches operating speed.

- **Seek mode**

During seek mode, the read/write actuator arm moves toward a specific position on the disc surface and does not execute a read or write operation. Servo electronics are active. Seek mode power is measured based on three random seek operations every 100 msec. This mode is not typical.

- **Read/write power and current**

Read/write power is measured with the heads on track, based on three 63 sector read or write operations every 100 msec.

- **Operating power and current**

Operating power is measured using 40 percent random seeks, 40 percent read/write mode (1 write for each 10 reads) and 20 percent drive idle mode.

- **Idle mode power**

Idle mode power is measured with the drive up to speed, with servo electronics active and with the heads in a random track location.

- **Standby mode**

During Standby mode, the drive accepts commands, but the drive is not spinning, and the servo and read/write electronics are in power-down mode.

**Table 2: DC power**

Power dissipation (watts)	Average (watts, 25° C)	5V typ amps
Spinup, typical	—	1.1
Idle, performance mode	2.0	
Idle, active	1.3	
Idle, low power mode	0.95	
Seeking	2.6	
Read	2.2	
Write	2.4	
Standby	0.26	
Sleep	0.26	

\*During periods of drive idle, some offline activity may occur according to the S.M.A.R.T. specification, which may increase acoustic and power to operational levels.

### 2.9.1.1 Typical current profile

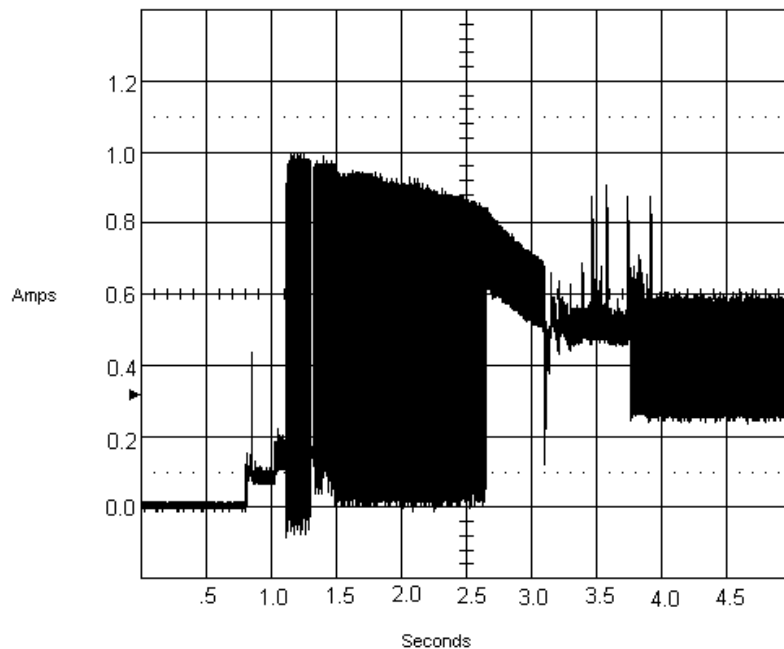

Figure 2. Typical 5V startup and operating current profile

### 2.9.2 Conducted noise

Input noise ripple is measured at the host system power supply across an equivalent 15-ohm resistive load on the +5 volt line.

Using 5-volt power, the drive is expected to operate with a maximum of 100 mV peak-to-peak square-wave injected noise at up to 10 MHz.

**Note.** Equivalent resistance is calculated by dividing the nominal voltage by the typical RMS read/write current.

### 2.9.3 Voltage tolerance

Voltage tolerance (including noise):

5V  $\pm$  5%

## 2.9.4 Power-management modes

The drive provides programmable power management to provide greater energy efficiency. In most systems, you can control power management through the system setup program. The drive features the following power-management modes:

**Table 3: Power management modes**

Power modes	Heads	Spindle	Buffer
Active (operating)	Tracking	Rotating	Full Power
Idle, performance	Tracking	Rotating	Self Refresh Low Power
Idle, active	Floating	Rotating	Self Refresh Low Power
Idle, low power	Parked	Rotating	Self Refresh Low Power
Standby	Parked	Stopped	Self Refresh Low Power
Sleep	Parked	Stopped	Self Refresh Low Power

- **Active mode**

The drive is in Active mode during the read/write and seek operations.

- **Idle mode**

The buffer remains enabled, and the drive accepts all commands and returns to Active mode any time disc access is necessary.

- **Standby mode**

The drive enters Standby mode when the host sends a Standby Immediate command. If the host has set the standby timer, the drive can also enter Standby mode automatically after the drive has been inactive for a specifiable length of time. The standby timer delay is established using a Standby or Idle command. In Standby mode, the drive buffer is in Self Refresh Low Power mode, the heads are parked and the spindle is at rest. The drive accepts all commands and returns to Active mode any time disc access is necessary.

- **Sleep mode**

The drive enters Sleep mode after receiving a Sleep command from the host. In Sleep mode, the drive buffer is in Self Refresh Low Power mode, the heads are parked and the spindle is at rest. The drive leaves Sleep mode after it receives a Hard Reset or Soft Reset from the host. After receiving a reset, the drive exits Sleep mode and enters Standby mode with all current translation parameters intact.

- **Idle and Standby timers**

Each time the drive performs an Active function (read, write or seek), the standby timer is reinitialized and begins counting down from its specified delay times to zero. If the standby timer reaches zero before any drive activity is required, the drive makes a transition to Standby mode. In both Idle and Standby mode, the drive accepts all commands and returns to Active mode when disc access is necessary.



## 2.10 Environmental specifications

### 2.10.1 Ambient temperature

Ambient temperature is defined as the temperature of the environment immediately surrounding the drive. Actual drive case temperature should not exceed 65°C (149°F) within the operating ambient conditions.

Above 1,000 feet (305 meters), the maximum temperature is derated linearly by 1°C every 1000 feet.

Operating:	5° to 55°C (41° to 131°F)
Nonoperating:	–40° to 70°C (–40° to 158°F)

### 2.10.2 Temperature gradient

Operating:	20°C per hour (68°F per hour max), without condensation
Nonoperating:	30°C per hour (86°F per hour max)

### 2.10.3 Humidity

#### 2.10.3.1 Relative humidity

Operating:	8% to 90% noncondensing (30% per hour max)
Nonoperating:	5% to 95% noncondensing (30% per hour max)

#### 2.10.3.2 Wet bulb temperature

Operating:	30°C (86°F max)
Nonoperating:	40°C (104°F max)

### 2.10.4 Altitude

Operating:	–304.8 m to 3,048 m (–1,000 ft to 10,000+ ft)
Nonoperating:	–304.8 m to 12,192 m (–1,000 ft to 40,000+ ft)

## 2.10.5 Shock

All shock specifications assume that the drive is mounted securely with the input shock applied at the drive mounting screws. Shock may be applied in the X, Y or Z axis.

### 2.10.5.1 Operating shock

These drives comply with the performance levels specified in this document when subjected to a maximum operating shock of 250 Gs based on half-sine shock pulses of 2 msec. Shocks should not be repeated more than two times per second.

### 2.10.5.2 Nonoperating shock

The nonoperating shock level that the drive can experience without incurring physical damage or degradation in performance when subsequently put into operation is 800 Gs based on a nonrepetitive half-sine shock pulse of 2 msec duration.

The nonoperating shock level that the drive can experience without incurring physical damage or degradation in performance when subsequently put into operation is 900 Gs based on a nonrepetitive half-sine shock pulse of 1 msec duration.

The nonoperating shock level that the drive can experience without incurring physical damage or degradation in performance when subsequently put into operation is 400 Gs based on a nonrepetitive half-sine shock pulse of 0.5 msec duration.

## 2.10.6 Vibration

All vibration specifications assume that the drive is mounted securely with the input vibration applied at the drive mounting screws. Vibration may be applied in the X, Y or Z axis.

### 2.10.6.1 Operating vibration

The following table lists the maximum vibration levels that the drive may experience while meeting the performance standards specified in this document.

5–500 Hz:	1.0 Gs (0 to peak). Max displacement may apply below 10 Hz.
-----------	---

### 2.10.6.2 Nonoperating vibration

The following table lists the maximum nonoperating vibration that the drive may experience without incurring physical damage or degradation in performance when subsequently put into operation.

5–500 Hz:	5.0 Gs (0 to peak). Max displacement may apply below 22 Hz.
-----------	---

## 2.11 Acoustics

Drive acoustics are measured as overall A-weighted acoustic sound power levels (no pure tones). All measurements are consistent with ISO document 7779. Sound power measurements are taken under essentially free-field conditions over a reflecting plane. For all tests, the drive is oriented with the cover facing upward.

**Note.** For seek mode tests, the drive is placed in seek mode only. The number of seeks per second is defined by the following equation:

$$(\text{Number of seeks per second} = 0.4 / (\text{average latency} + \text{average access time}))$$

**Table 4: Drive level acoustics**

Acoustic mode	
Idle*	Seek
2.5 bels (typ)	2.9 bels (typ)
2.8 bels (max)	3.1 bels (max)

\*During periods of drive idle, some offline activity may occur according to the S.M.A.R.T. specification, which may increase acoustic and power to operational levels.

## 2.12 Electromagnetic immunity

When properly installed in a representative host system, the drive operates without errors or degradation in performance when subjected to the radio frequency (RF) environments defined in the following table:

**Table 5: Electromagnetic immunity**

Test	Description	Performance level	Reference standard
Electrostatic discharge	Contact, HCP, VCP: ± 4 kV; Air: ± 8 kV	B	EN 61000-4-2: 95
Radiated RF immunity	80 to 1,000 MHz, 3 V/m, 80% AM with 1 kHz sine 900 MHz, 3 V/m, 50% pulse modulation @ 200 Hz	A	EN 61000-4-3: 96 ENV 50204: 95
Electrical fast transient	± 1 kV on AC mains, ± 0.5 kV on external I/O	B	EN 61000-4-4: 95
Surge immunity	± 1 kV differential, ± 2 kV common, AC mains	B	EN 61000-4-5: 95
Conducted RF immunity	150 kHz to 80 MHz, 3 Vrms, 80% AM with 1 kHz sine	A	EN 61000-4-6: 97
Voltage dips, interrupts	0% open, 5 seconds 0% short, 5 seconds 40%, 0.10 seconds 70%, 0.01 seconds	C C C B	EN 61000-4-11: 94

## 2.13 Reliability

Measurement type	Specification
Nonrecoverable read errors	1 per 10 <sup>14</sup> bits read, max
Annualized Failure Rate (AFR)	0.73%
Load/Unload (U/UL)  40°C, 50% relative humidity  32°C, 80% relative humidity 5°C, 80% relative humidity 5°C, 10% relative humidity 55°C, 16% relative humidity	  600,000 software-controlled power on/off cycles 20,000 hard power on/off cycles  100,000 software-controlled power on/off cycles 20,000 hard power on/off cycles
Service Life	5 Years
Warranty	5 Years on distribution units. To determine the warranty for a specific drive, use a web browser to access the following web page: <a href="http://www.seagate.com/support/service/">www.seagate.com/support/service/</a> From this page, click on the "Verify Your Warranty" link. You will be asked to provide the drive serial number, model number (or part number) and country of purchase. The system will display the warranty information for your drive.

## 2.14 Agency certification

### 2.14.1 Safety certification

The drives are recognized in accordance with UL 1950 and CSA C22.2 (950) and meet all applicable sections of IEC950 and EN 60950 as tested by TUV North America.

### 2.14.2 Electromagnetic compatibility

Hard drives that display the CE mark comply with the European Union (EU) requirements specified in the Electromagnetic Compatibility Directive (89/336/EEC). Testing is performed to the levels specified by the product standards for Information Technology Equipment (ITE). Emission levels are defined by EN 55022, Class B and the immunity levels are defined by EN 55024.

Seagate uses an independent laboratory to confirm compliance with the EC directives specified in the previous paragraph. Drives are tested in representative end-user systems. Although CE-marked Seagate drives comply with the directives when used in the test systems, we cannot guarantee that all systems will comply with the directives. The drive is designed for operation inside a properly designed enclosure, with properly shielded I/O cable (if necessary) and terminators on all unused I/O ports. Computer manufacturers and system integrators should confirm EMC compliance and provide CE marking for their products.

## Korean RRL

If these drives have the Korea Ministry of Information and Communication (MIC) logo, they comply with paragraph 1 of Article 11 of the Electromagnetic Compatibility control Regulation and meet the Electromagnetic Compatibility (EMC) Framework requirements of the Radio Research Laboratory (RRL) Ministry of Information and Communication Republic of Korea.

These drives have been tested and comply with the Electromagnetic Interference/Electromagnetic Susceptibility (EMI/EMS) for Class B products. Drives are tested in a representative, end-user system by a Korean-recognized lab.

- EUT name (model numbers): ST910021A, ST980825A and ST96023A.
- Certificate numbers:

ST910021A	E-H011-03-xxxx(B) (Pending)
ST980825A	E-H011-03-xxxx(B) (Pending)
ST96023A	E-H011-03-xxxx(B) (Pending)
ST94015A	E-H011-03-xxxx(B) (Pending)
- Trade name or applicant: Seagate Technology
- Manufacturing date: June 2005
- Manufacturer/nationality: USA, Singapore and China

## Australian C-Tick (N176)

If these models have the C-Tick marking, they comply with the Australia/New Zealand Standard AS/NZS3548 1995 and meet the Electromagnetic Compatibility (EMC) Framework requirements of the Australian Communication Authority (ACA).

### 2.14.3 FCC verification

These drives are intended to be contained solely within a personal computer or similar enclosure (not attached as an external device). As such, each drive is considered to be a subassembly even when it is individually marketed to the customer. As a subassembly, no Federal Communications Commission verification or certification of the device is required.

Seagate Technology LLC has tested this device in enclosures as described above to ensure that the total assembly (enclosure, disc drive, motherboard, power supply, etc.) does comply with the limits for a Class B computing device, pursuant to Subpart J, Part 15 of the FCC rules. Operation with noncertified assemblies is likely to result in interference to radio and television reception.

**Radio and television interference.** This equipment generates and uses radio frequency energy and if not installed and used in strict accordance with the manufacturer's instructions, may cause interference to radio and television reception.

This equipment is designed to provide reasonable protection against such interference in a residential installation. However, there is no guarantee that interference will not occur in a particular installation. If this equipment does cause interference to radio or television, which can be determined by turning the equipment on and off, you are encouraged to try one or more of the following corrective measures:

- Reorient the receiving antenna.
- Move the device to one side or the other of the radio or TV.
- Move the device farther away from the radio or TV.
- Plug the computer into a different outlet so that the receiver and computer are on different branch outlets.

If necessary, you should consult your dealer or an experienced radio/television technician for additional suggestions. You may find helpful the following booklet prepared by the Federal Communications Commission: *How to Identify and Resolve Radio-Television Interference Problems*. This booklet is available from the Superintendent of Documents, U.S. Government Printing Office, Washington, DC 20402. Refer to publication number 004-000-00345-4.

## 2.15 Environmental protection

Seagate designs its products to meet environmental protection requirements worldwide, including regulations restricting certain chemical substances.

### 2.15.1 European Union Restriction of Hazardous Substances (RoHS)

The European Union Restriction of Hazardous Substances (RoHS) Directive restricts the presence of chemical substances, including Lead (Pb), in electronic products effective July 2006.

A number of parts and materials in Seagate products are procured from external suppliers. We rely on the representations of our suppliers regarding the presence of RoHS substances in these parts and materials. Our supplier contracts require compliance with our chemical substance restrictions, and our suppliers document their compliance with our requirements by providing material content declarations for all parts and materials for the disc drives documented in this publication. Current supplier declarations include disclosure of the inclusion of any RoHS-regulated substance in such parts or materials.

Seagate also has internal systems in place to ensure ongoing compliance with the RoHS Directive and all laws and regulations which restrict chemical content in electronic products. These systems include standard operating procedures that ensure that restricted substances are not utilized in our manufacturing operations, laboratory analytical validation testing, and an internal auditing process to ensure that all standard operating procedures are complied with.

### 2.15.2 China Restriction of Hazardous Substances (RoHS) Directive

#### 2.16.2 中国限制危险物品的指令

This product has an Environmental Protection Use Period (EPUP) of 20 years. The following table contains information mandated by China's "Marking Requirements for Control of Pollution Caused by Electronic Information Products" Standard.



该产品具有20年的环境保护使用周期（EPUP）。下表包含了中国“电子产品所导致的污染的控制的记号要求”所指定的信息。

Name of Parts 部件名称	Toxic or Hazardous Substances or Elements 有毒有害物质或元素					
	Lead 铅 (Pb)	Mercury 汞 (Hg)	Cadmium 镉 (Cd)	Hexavalent Chromium 六价铬 (Cr6+)	Polybrominated Biphenyl 多溴联苯 (PBB)	Polybrominated Diphenyl Ether 多溴二苯醚 (PBDE)
PCBA	X	O	O	O	O	O
HDA	X	O	O	O	O	O

"O" indicates the hazardous and toxic substance content of the part (at the homogenous material level) is lower than the threshold defined by the China RoHS MCV Standard.

“O”表示该部件（于同类物品程度上）所含的危险和有毒物质低于中国RoHS MCV标准所定义的门槛值。

"X" indicates the hazardous and toxic substance content of the part (at the homogenous material level) is over the threshold defined by the China RoHS MCV Standard.

“X”表示该部件（于同类物品程度上）所含的危险和有毒物质超出中国RoHS MCV标准所定义的门槛值。





## 3.0 Configuring and mounting the drive

---

This section contains the specifications and instructions for configuring and mounting the drive.

### 3.1 Handling and static discharge precautions

After unpacking, and before installation, the drive may be exposed to potential handling and electrostatic discharge (ESD) hazards. Observe the following standard handling and static-discharge precautions:

- Keep the drive in the electrostatic discharge (ESD) bag until you are ready for installation to limit the drive's exposure to ESD.
- Before handling the drive, put on a grounded wrist strap, or ground yourself frequently by touching the metal chassis of a computer that is plugged into a grounded outlet. Wear a grounded wrist strap throughout the entire installation procedure.
- Handle the drive only by its edges or frame.
- The drive is fragile—handle it with care. Do not press down on the drive top cover.
- Always rest the drive on a padded, antistatic surface until you mount it in the computer.
- Do not touch the connector pins or the printed circuit board.
- Do not remove the factory-installed labels from the drive or cover them with additional labels. Removal voids the warranty. Some factory-installed labels contain information needed to service the drive. Other labels are used to seal out dirt and contamination.

### 3.2 Jumper settings

#### 3.2.1 Master/slave configuration

Use the options jumper block shown in Figure 3 to configure the drive for operation. This jumper block is the 4-pin header adjacent to pins 1 and 2 of the I/O signal pins. For additional information about using the Cable select option, see section 3.2.2.

The “Master or single drive” option is the factory default setting.

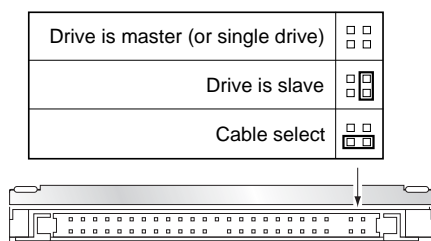

Figure 3. Jumper settings

### 3.2.2 Cable-select option

Computers that use cable select determine the master and slave drives by selecting or deselecting pin 28, CSEL, on the interface bus. Master and slave drives are determined by their physical position on the cable. To enable cable select, set a jumper as shown in Figure 3. Refer to your computer manual to determine whether your computer supports this option.

### 3.3 Drive mounting

You can mount the drive using four screws in the side-mounting holes or four screws in the bottom-mounting holes. See Figure 4 for drive mounting dimensions. Follow these important mounting precautions when mounting the drive:

- Allow a minimum clearance of 0.030 inches (0.76 mm) around the entire perimeter of the drive for cooling.
- Use only M3 UNC mounting screws.
- Do not overtighten the mounting screws (maximum torque: 4.0 inch-lb).
- Four (4) threads (0.080 inches) minimum screw engagement recommended.

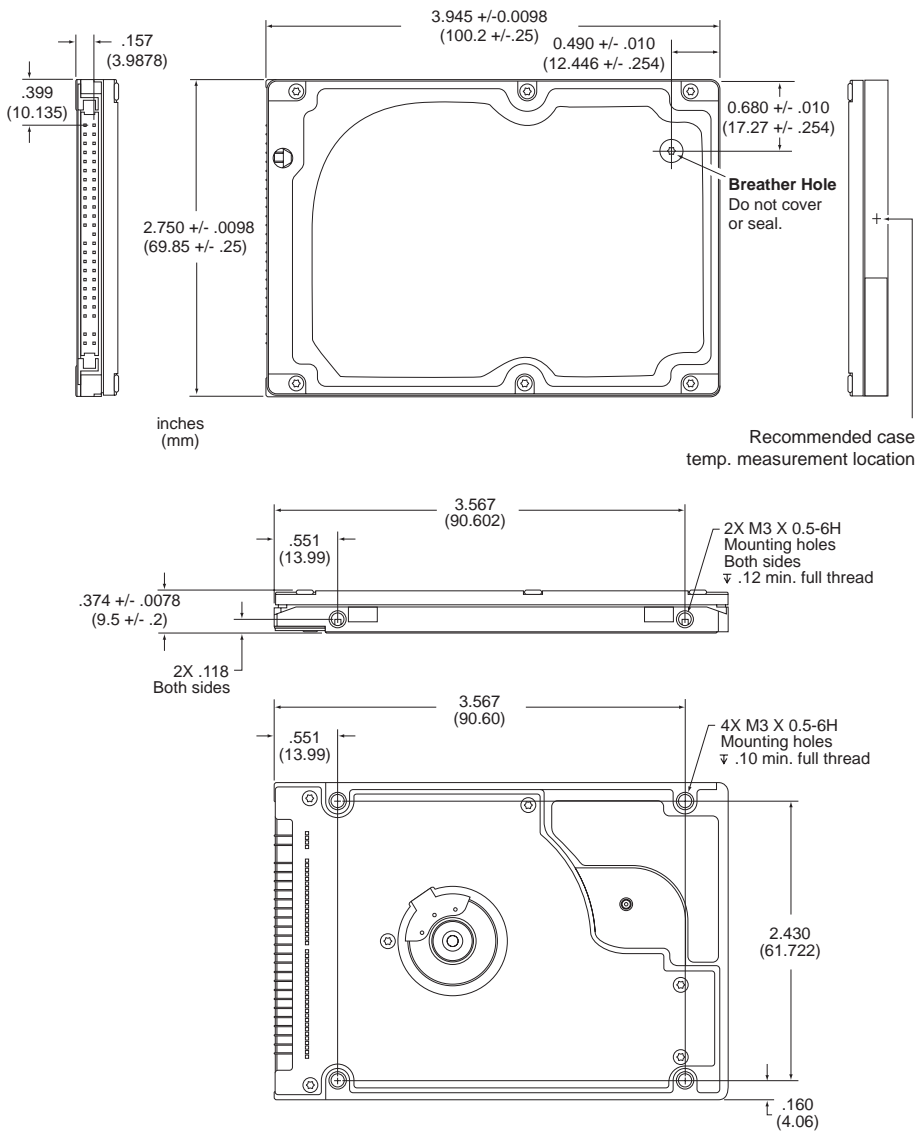

Figure 4. Mounting dimensions—top, side and end view

## 4.0 ATA interface

These drives use the industry-standard ATA task file interface that supports 16-bit data transfers. It supports ATA programmed input/output (PIO) modes 0–4; multiword DMA modes 0–2, and Ultra DMA modes 0–5. The drive also supports the use of the IORDY signal to provide reliable high-speed data transfers.

For detailed information about the ATA interface, refer to the draft of *AT Attachment with Packet Interface Extension (ATA/ATAPI-6)*, *NCITS T13 1410D*, subsequently referred to as the *Draft ATA-6 Standard*.

### 4.1 ATA interface signals and connector pins

The following table summarizes the signals on the 44-pin ATA interface connector. For a detailed description of these signals, refer to the *Draft ATA-6 Standard*.

**Table 6: Connector signals**

Signal Name	Connector Contact	Cable Conductor
RESET-	1	1
DD7	3	3
DD6	5	5
DD5	7	7
DD4	9	9
DD3	11	11
DD2	13	13
DD1	15	15
DD0	17	17
Ground	19	19
DMARQ	21	21
DIOW-	23	23
DIOR-	25	25
IORDY	27	27
DMACK-	29	29
INTRQ	31	31
DA1	33	33
DA0	35	35
CS1FX-	37	37
DASP-	39	39
+5 V (Logic)	41	41
Ground (Return)	43	43

Cable Conductor	Connector Contact	Signal Name
2	2	Ground
4	4	DD8
6	6	DD9
8	8	DD10
10	10	DD11
12	12	DD12
14	14	DD13
16	16	DD14
18	18	DD15
20	20	(keypin)
22	22	Ground
24	24	Ground
26	26	Ground
28	28	PSYNC:CSEL
30	30	Ground
32	32	IOCS16-
34	34	PDIAG-
36	36	DA2
38	38	CS3FX-
40	40	Ground
42	42	+5V (Motor)
44	44	No connection

#### 4.1.1 Supported ATA commands

The following table lists ATA-standard commands that the drive supports. For a detailed description of the ATA commands, refer to the *Draft ATA-6 Standard*.

**Table 7: Supported commands**

Command name	Command code (in hex)
<b>ATA-standard commands</b>	
ATA Device Configuration Overlay	B1 <sub>H</sub>
ATA Service	A2 <sub>H</sub>
Check Power Mode	98 <sub>H</sub> , E5 <sub>H</sub>
Download Microcode	92 <sub>H</sub>
Execute Device Diagnostics	90 <sub>H</sub>
Flush Cache	E7 <sub>H</sub>
Flush Cache Extended	EA <sub>H</sub>
Format Track (Legacy)	50 <sub>H</sub>
Identify Device	EC <sub>H</sub>
Idle	97 <sub>H</sub> , E3 <sub>H</sub>
Idle Immediate	95 <sub>H</sub> , E1 <sub>H</sub>
Initialize Device Parameters	91 <sub>H</sub>
Read Buffer	E4 <sub>H</sub>
Read DMA	C8 <sub>H</sub> , C9 <sub>H</sub>
Read DMA Extended	25 <sub>H</sub>
Read Log Extended	22 <sub>H</sub>
Read Multiple	C4 <sub>H</sub>
Read Multiple Extended	29 <sub>H</sub>
Read Native Max Address	F8 <sub>H</sub>
Read Native Max Address Extended	27 <sub>H</sub>
Read Sectors	20 <sub>H</sub> , 21 <sub>H</sub>
Read Sectors Extended	24 <sub>H</sub>
Read Verify Sectors	40 <sub>H</sub> , 41 <sub>H</sub>
Read Verify Sectors Extended	42 <sub>H</sub>
Recalibrate	10 <sub>H</sub>
Security Disable Password	F6 <sub>H</sub>
Security Erase Prepare	F3 <sub>H</sub>
Security Erase Unit	F4 <sub>H</sub>
Security Freeze Lock	F5 <sub>H</sub>
Security Set Password	F1 <sub>H</sub>

**Table 7: Supported commands**

Command name	Command code (in hex)
Security Unlock	F2 <sub>H</sub>
Seek	70 <sub>H</sub>
Set Drive Parameters	91 <sub>H</sub>
Set Features	EF <sub>H</sub>
Set Max Address	F9 <sub>H</sub>
Note: Individual Set Max commands are identified by the value placed in the Set Max Features register as defined to the right.	Address: 00 <sub>H</sub> Password: 01 <sub>H</sub> Lock: 02 <sub>H</sub> Unlock: 03 <sub>H</sub> Freeze Lock: 04 <sub>H</sub>
Set Multiple Mode	C6 <sub>H</sub>
Sleep	99 <sub>H</sub> , E6 <sub>H</sub>
S.M.A.R.T.	B0 <sub>H</sub>
Standby	96 <sub>H</sub> , E2 <sub>H</sub>
Standby Immediate	94 <sub>H</sub> , E0 <sub>H</sub>
Vendor Unique	9A <sub>H</sub> , FA <sub>H</sub> , FB <sub>H</sub>
Write Buffer	E8 <sub>H</sub>
Write DMA	CA <sub>H</sub> , CB <sub>H</sub>
Write DMA Extended	35 <sub>H</sub>
Write Log Extended	32 <sub>H</sub>
Write Multiple	C5 <sub>H</sub>
Write Multiple Extended	39 <sub>H</sub>
Write Sectors	30 <sub>H</sub> , 31 <sub>H</sub>
Write Sectors Extended	34 <sub>H</sub>
<b>ATA-standard power-management commands</b>	
Check Power Mode	98 <sub>H</sub> or E5 <sub>H</sub>
Idle	97 <sub>H</sub> or E3 <sub>H</sub>
Idle Immediate	95 <sub>H</sub> or E1 <sub>H</sub>
Sleep	99 <sub>H</sub> or E6 <sub>H</sub>
Standby	96 <sub>H</sub> or E2 <sub>H</sub>
Standby Immediate	94 <sub>H</sub> or E0 <sub>H</sub>
<b>ATA-standard security commands</b>	
Security Set Password	F1 <sub>H</sub>
Security Unlock	F2 <sub>H</sub>
Security Erase Prepare	F3 <sub>H</sub>
Security Erase Unit	F4 <sub>H</sub>

**Table 7: Supported commands**

<b>Command name</b>	<b>Command code (in hex)</b>
Security Freeze Lock	F5 <sub>H</sub>
Security Disable Password	F6 <sub>H</sub>

#### 4.1.2 Identify Device command

The Identify Device command (command code EC<sub>H</sub>) transfers information about the drive to the host following power up. The data is organized as a single 512-byte block of data, whose contents are shown in the table on page 27. All reserved bits or words should be set to zero. Parameters listed with an “x” are drive-specific or vary with the state of the drive. See Section 2.0 on page 3 for default parameter settings.

The following commands contain drive-specific features that may not be included in the *Draft ATA-6 Standard*.

Word	Description	Value
0	Configuration information: <ul style="list-style-type: none"> <li>• Bit 15: 0 = ATA; 1 = ATAPI</li> <li>• Bit 7: removable media</li> <li>• Bit 6: removable controller</li> <li>• Bit 0: reserved</li> </ul>	0C5A <sub>H</sub>
1	Number of logical cylinders	16,383
2	ATA-reserved	0000 <sub>H</sub>
3	Number of logical heads	16
4	Retired	0000 <sub>H</sub>
5	Retired	0000 <sub>H</sub>
6	Number of logical sectors per logical track: 63	003F <sub>H</sub>
7–9	Retired	0000 <sub>H</sub>
10–19	Serial number: (20 ASCII characters, 0000 <sub>H</sub> = none)	ASCII
20	Retired	0000 <sub>H</sub>
21	Retired	0400 <sub>H</sub>
22	Obsolete	0000 <sub>H</sub>
23–26	Firmware revision (8 ASCII character string, padded with blanks to end of string)	x.xx
27–46	Drive model number: (40 ASCII characters, padded with blanks to end of string)	ST910021A, ST980825A ST96023A ST94015A
47	(Bits 7–0) Maximum sectors per interrupt on Read multiple and Write multiple (16)	8010 <sub>H</sub>
48	Reserved	0000 <sub>H</sub>
49	Standard Standby timer, IORDY supported and may be disabled	2F00 <sub>H</sub>
50	ATA-reserved	0000 <sub>H</sub>
51	PIO data-transfer cycle timing mode	0200 <sub>H</sub>
52	Retired	0200 <sub>H</sub>
53	Words 54–58, 64–70 and 88 are valid	0007 <sub>H</sub>
54	Number of current logical cylinders	xxxx <sub>H</sub>
55	Number of current logical heads	xxxx <sub>H</sub>
56	Number of current logical sectors per logical track	xxxx <sub>H</sub>
57–58	Current capacity in sectors	xxxx <sub>H</sub>

Word	Description	Value
59	Number of sectors transferred during a Read Multiple or Write Multiple command	xxxx <sub>H</sub>
60–61	Total number of user-addressable LBA sectors available (see Section 2.2 for related information)	ST910021A = 195,371,568 ST980825A = 156,301,488 ST96023A = 117,210,240 ST94015A = 78,140,160
62	Retired	0000 <sub>H</sub>
63	Multiword DMA active and modes supported (see note following this table)	xx07 <sub>H</sub>
64	Advanced PIO modes supported (modes 3 and 4 supported)	0003 <sub>H</sub>
65	Minimum multiword DMA transfer cycle time per word (120 nsec)	0078 <sub>H</sub>
66	Recommended multiword DMA transfer cycle time per word (120 nsec)	0078 <sub>H</sub>
67	Minimum PIO cycle time without IORDY flow control (240 nsec)	00F0 <sub>H</sub>
68	Minimum PIO cycle time with IORDY flow control (120 nsec)	0078 <sub>H</sub>
69–74	ATA-reserved	0000 <sub>H</sub>
75	Queue depth	0000 <sub>H</sub>
76–79	ATA-reserved	0000 <sub>H</sub>
80	Major version number	007E <sub>H</sub>
81	Minor version number	0000 <sub>H</sub>
82	Command sets supported	346B <sub>H</sub>
83	Command sets supported	7D01 <sub>H</sub>
84	Command sets support extension	4003 <sub>H</sub>
85	Command sets enabled	34xx <sub>H</sub>
86	Command sets enabled	3xxx <sub>H</sub>
87	Command sets enable extension	4003 <sub>H</sub>
88	Ultra DMA support and current mode (see note following this table)	xx3F <sub>H</sub>
89	Security erase time	0000 <sub>H</sub>
90	Enhanced security erase time	0000 <sub>H</sub>
91	Advanced power management value	0040 <sub>H</sub>
92	Master password revision code	FFFE <sub>H</sub>
93	Hardware reset value (see description following this table)	xxxx <sub>H</sub>
94	Auto acoustic management setting	xxxx <sub>H</sub>
95–127	ATA-reserved	0000 <sub>H</sub>
128	Security status	0001 <sub>H</sub>
129–159	Seagate-reserved	xxxx <sub>H</sub>



Word	Description	Value
160–254	ATA-reserved	0000 <sub>H</sub>
255	Integrity word	xxA5 <sub>H</sub>

**Note.** See the bit descriptions below for words 63, 88, 93 and 94 of the Identify Drive data:

**Description (if bit is set to 1)**

Bit	Word 63
0	Multiword DMA mode 0 is supported.
1	Multiword DMA mode 1 is supported.
2	Multiword DMA mode 2 is supported.
8	Multiword DMA mode 0 is currently active.
9	Multiword DMA mode 1 is currently active.
10	Multiword DMA mode 2 is currently active.
Bit	Word 88
0	Ultra DMA mode 0 is supported.
1	Ultra DMA mode 1 is supported.
2	Ultra DMA mode 2 is supported.
3	Ultra DMA mode 3 is supported.
4	Ultra DMA mode 4 is supported.
8	Ultra DMA mode 0 is currently active.
9	Ultra DMA mode 1 is currently active.
10	Ultra DMA mode 2 is currently active.
11	Ultra DMA mode 3 is currently active.
12	Ultra DMA mode 4 is currently active.
13	Ultra DMA mode 5 is currently active.
Bit	Word 93
13	1 = 80-conductor cable detected, CBLID above V <sub>IH</sub> 0 = 40-conductor cable detected, CBLID below V <sub>IL</sub>

### 4.1.3 Set Features command

This command controls the implementation of various features that the drive supports. When the drive receives this command, it sets BSY, checks the contents of the Features register, clears BSY and generates an interrupt. If the value in the register does not represent a feature that the drive supports, the command is aborted. Power-on default has the read look-ahead and write caching features enabled. The acceptable values for the Features register are defined as follows:

**Table 8: Features register values**

02 <sub>H</sub>	Enable write cache ( <i>default</i> ).	
03 <sub>H</sub>	Set transfer mode (based on value in Sector Count register).	
	Sector Count register values:	
	00 <sub>H</sub>	Set PIO mode to default (PIO mode 2).
	01 <sub>H</sub>	Set PIO mode to default and disable IORDY (PIO mode 2).
	08 <sub>H</sub>	PIO mode 0
	09 <sub>H</sub>	PIO mode 1
	0A <sub>H</sub>	PIO mode 2
	0B <sub>H</sub>	PIO mode 3
	0C <sub>H</sub>	PIO mode 4 ( <i>default</i> )
	20 <sub>H</sub>	Multiword DMA mode 0
	21 <sub>H</sub>	Multiword DMA mode 1
	22 <sub>H</sub>	Multiword DMA mode 2
	40 <sub>H</sub>	Ultra DMA mode 0
	41 <sub>H</sub>	Ultra DMA mode 1
	42 <sub>H</sub>	Ultra DMA mode 2
	43 <sub>H</sub>	Ultra DMA mode 3
	44 <sub>H</sub>	Ultra DMA mode 4
	45 <sub>H</sub>	Ultra DMA mode 5
05 <sub>H</sub>	Enable advanced power management	
55 <sub>H</sub>	Disable read look-ahead (read cache) feature.	
82 <sub>H</sub>	Disable write cache.	
AA <sub>H</sub>	Enable read look-ahead (read cache) feature ( <i>default</i> ).	
F1 <sub>H</sub>	Report full capacity available	

**Note.** At power-on, or after a hardware or software reset, the default values of the features are as indicated above.

## 5.0 Seagate Technology support services

---

### Internet

For information regarding Seagate products and services, visit [www.seagate.com](http://www.seagate.com). Worldwide support is available 24 hours daily by email for your questions.

### Presales Support:

Presales@Seagate.com

### Technical Support:

DiscSupport@Seagate.com

### Warranty Support:

<http://www.seagate.com/support/service/index.html>

### mySeagate

my.seagate.com is the industry's first Web portal designed specifically for OEMs and distributors. It provides self-service access to critical applications, personalized content and the tools that allow our partners to manage their Seagate account functions. Submit pricing requests, orders and returns through a single, password-protected Web interface-anytime, anywhere in the world.

### spp.seagate.com

spp.seagate.com supports Seagate resellers with product information, program benefits and sales tools. You may register for customized communications that are not available on the web. These communications contain product launch, EOL, pricing, promotions and other channel-related information. To learn more about the benefits or to register, go to spp.seagate.com, any time, from anywhere in the world.

## Seagate Service Centers

### Presales Support

Our Presales Support staff can help you determine which Seagate products are best suited for your specific application or computer system, as well as product availability and compatibility.

### Technical Support

Seagate technical support is available to assist you online at [support.seagate.com](http://support.seagate.com) or through one of our call centers. Have your system configuration information and your "ST" model number available.

**SeaTDD™ (+1-405-324-3655)** is a telecommunications device for the deaf (TDD). You can send questions or comments 24 hours daily and exchange messages with a technical support specialist during normal business hours for the call center in your region.

## Customer Service Operations

### Warranty Service

Seagate offers worldwide customer support for Seagate products. Seagate distributors, OEMs and other direct customers should contact their Seagate Customer Service Operations (CSO) representative for warranty-related issues. Resellers or end users of drive products should contact their place of purchase or Seagate warranty service for assistance. Have your serial number and model or part number available.

### Data Recovery Services

Seagate offers data recovery services for all formats and all brands of storage media. Our data recovery services labs are currently located throughout the world. . Additional information, including an online request form and data loss prevention resources, is available at <http://services.seagate.com/index.aspx>

### Authorized Service Centers

Seagate Service Centers are available on a global basis for the return of defective products. Contact your customer support representative for the location nearest you.

### USA/Canada/Latin America support services

For an extensive list of telephone numbers to technical support, presales and warranty service in USA/Canada/Latin America, including business hours, go to the "Contact Us" page on [www.seagate.com](http://www.seagate.com).

## Global Customer Support

### Presales, Technical, and Warranty Support

Call Center	Toll-free	Direct dial
USA, Canada, and Mexico	1-800-SEAGATE	+1-405-324-4700

### Data Recovery Services

Call Center	Toll-free	Direct dial	FAX
USA, Canada, and Mexico	1-800-475-01435	+1-905-474-2162	1-800-475-0158 +1-905-474-2459

## Europe, the Middle East and Africa Support Services

For an extensive list of telephone numbers to technical support, presales and warranty service in Europe, the Middle East and Africa, go to the "Contact Us" page on [www.seagate.com](http://www.seagate.com).

## Asia/Pacific Support Services

For an extensive list of telephone numbers to technical support, presales and warranty service in Asia/Pacific, go to the "Contact Us" page on [www.seagate.com](http://www.seagate.com).

# Index

## A

- acoustics 13
- Active mode 10
- radio frequency (RF) 13
- AFR 4, 14
- agency certification (regulatory) 14
- altitude 11
- ambient conditions 3
- ambient temperature 7, 11
- Annualized Failure Rate (AFR) 4, 14
- areal density 6
- ATA interface 21
- ATA-standard commands 22
- Australian C-Tick 15
- autodetection 1
- average seek time 7

## B

- BPI 6
- buffer 1, 6
- burst 1

## C

- cable select 1
- cable-select option 20
- cache 1, 6
- case temperature 11
- CE mark 14
- certification 14
- Check Power Mode 23
- China RoHS directive 16
- commands 22
- compliance 14
- conducted noise 9
- conducted RF immunity 13
- configuring the drive 19
- connector pins 21
- CSA C22.2 (950) 14
- CSEL 20
- C-Tick 15
- current profile 9
- cycles 14

## D

- data-transfer rates 1
- DC power 8
- density 6
- diagnostic software 1
- discs 5
- dissipation 8

- Download Microcode 22
- drive diagnostics 7
- drive monitoring 1
- drive self-test 1

## E

- electrical fast transient 13
- electromagnetic compatibility 14
- Electromagnetic Compatibility Directive 14
- electromagnetic immunity 13
- electrostatic discharge 13
- EMC compliance 14
- EN 60950 14
- enclosures 15
- environmental specifications 11
- error-correction algorithms 1
- errors 14
- European Union 14
- European Union Restriction of Hazardous Substances 16
- Execute Device Diagnostics 22

## F

- FCC verification 15
- Features register 28
- Flush Cache 22
- Flush Cache Extended 22
- formatted capacity 5
- frequency 13

## G

- guaranteed sectors 5

## H

- handling 19
- heads 1, 5
- height 6
- humidity 11

## I

- I/O data-transfer rate 6
- Identify Device 22
- Identify Device command 25
- Idle 8, 23
- Idle and Standby timers 10
- Idle Immediate 23
- Idle mode 10
- Idle mode power 8
- IEC950 14
- Information Technology Equipment 14
- Initialize Device Parameters 22
- interface 6, 21
- interface signals 21

interference 15  
interleave 6  
internal data-transfer rate OD 6  
ISO document 7779 13

## J

jumper settings 19

## K

Korean RRL 15

## L

LBA mode 5  
length 6  
Load/Unload 14  
logical geometry 5

## M

master/slave 1  
Master/slave configuration 19  
maximum temperature 11  
modes 21  
monitoring 1  
mounting the drive 19, 20

## N

noise 9  
nominal power 3  
nonoperating shock 12  
nonoperating vibration 12  
nonrecoverable read errors 14

## O

operating power and current 8  
operating shock 12  
operating vibration 12

## P

physical characteristics 6  
physical organization 5  
pins 21  
PIO 21  
power consumption 8  
power dissipation 8  
power management 10  
power on/off cycles 14  
power specifications 8  
power-management commands 23  
power-management modes 10  
Power-on to Ready 7  
precautions 20  
programmable power management 10

## R

radiated RF immunity 13  
radio and television interference 15  
random track location 8  
Read Buffer 22  
Read DMA 22  
Read DMA Extended 22  
read errors 14  
Read Multiple 1, 22  
Read Multiple Extended 22  
Read Native Max Address 22  
Read Native Max Address Extended 22  
Read Sectors 22  
Read Sectors Extended 22  
Read Verify Sectors 22  
Read Verify Sectors Extended 22  
read/write heads 5  
read/write power and current 8  
recording and interface technology 6  
recording density 6  
recording heads 1  
recording method 6  
register 28  
relative humidity 11  
reliability 14  
resistance 9  
RF 13  
RoHS 16

## S

S.M.A.R.T. 23  
S.M.A.R.T. drive monitoring 1  
safety certification 14  
screws 20  
SeaTools 1  
sectors 5  
security commands 23  
Security Disable Password 24  
Security Erase Prepare 23  
Security Erase Unit 23  
Security Freeze Lock 24  
Security Set Password 23  
Security Unlock 23  
Seek 23  
seek mode 8  
seek time 7  
Seeking 8  
Service Life 14  
servo electronics 8  
Set Features 23  
Set Features command 28  
Set Max 23  
Set Multiple Mode 23  
shock 12

- signals 21
- single-track seeks 7
- Sleep 8, 23
- Sleep mode 10
- sound 13
- specifications 3
- spindle speed 6
- Spinup 8
- spinup power 8
- Standby 8, 23
- Standby Immediate 23
- Standby mode 8, 10
- Standby to Ready 7
- static-discharge precautions 19
- subassembly 15
- support services 29
- surge immunity 13

## **T**

- technical support services 29
- temperature 11
- temperature gradient 11
- time to ready 7
- timers 10
- TMR 1
- track density 6
- track-to-track seek time 7
- TUV North America 14

## **U**

- UL 1950 14

## **V**

- vibration 12
- voltage 9
- voltage dips, interrupts 13
- voltage tolerance 9

## **W**

- Warranty 14
- weight 6
- wet bulb temperature 11
- width 6
- Write Buffer 23
- Write DMA 23
- Write DMA Extended 23
- Write Multiple 1, 23
- Write Multiple Extended 23
- Write Sectors 23
- Write Sectors Extended 23









**Seagate Technology LLC**  
**920 Disc Drive, Scotts Valley, California 95066-4544, USA**  
*Publication Number: 100320518, Rev. C, Printed in USA*