



LaCie 2big Dock

User Manual



Click here to access an up-to-date online version of this document. You will also find the most recent content as well as expandable illustrations, easier navigation, and search capability.

Contents

| | | |
|----------|---|-----------|
| 1 | Welcome | 6 |
| | Box content | 6 |
| | Minimum system requirements | 6 |
| | • Ports | 6 |
| | • Operating system | 6 |
| | • Minimum free disk space | 6 |
| 2 | System Overview | 7 |
| | Views | 7 |
| | • Front view | 7 |
| | • Rear panel view | 7 |
| | Storage management | 8 |
| 3 | Getting Started | 9 |
| | Connect power cable | 9 |
| | Connect to computer | 9 |
| | Set up LaCie 2big Dock | 10 |
| | • Start here | 10 |
| | • Register your device | 11 |
| | • Download Toolkit | 12 |
| | • Install Toolkit | 12 |
| | Storage format | 13 |
| | Disconnecting the drive | 13 |
| 4 | Use Toolkit to Set Up RAID, Import Files, and More | 14 |
| | Set up a RAID array | 14 |
| | Automated file imports | 14 |
| | LED controls | 14 |
| 5 | Operation | 15 |
| | Power on | 15 |
| | Power off | 15 |
| | Power saving mode | 15 |
| | • Power-saving mode: daisy chain | 16 |
| | • Power-saving mode: USB 3.2 Gen 2 hub | 16 |
| | • Power-saving mode: managed by the PC/Mac | 16 |
| | • Receiving power | 17 |
| | Short push | 17 |
| | Long push | 17 |
| | Removing the Thunderbolt cable during operation | 17 |

| | |
|---|-----------|
| Operation and heat management | 17 |
| Position | 18 |
| 6 System LEDs | 19 |
| LED locations | 19 |
| LED behavior | 19 |
| 7 Safely Remove Device From Your Computer | 21 |
| Windows | 21 |
| Mac | 21 |
| • Eject via Finder window | 21 |
| • Eject via Desktop | 21 |
| 8 Docking Features | 23 |
| USB 3.2 Gen 2 | 23 |
| • Connecting a device to the USB 3.2 hub | 23 |
| • Safely ejecting and disconnecting a device from the USB 3.2 hub | 23 |
| • macOS | 24 |
| • Windows | 24 |
| Secure Digital Extended Capacity (SDXC) memory card reader | 24 |
| • Reading an SD memory card | 24 |
| • Safely ejecting and removing an SD memory card | 25 |
| • Toolkit | 25 |
| • macOS | 25 |
| • Windows | 25 |
| CFast 2.0 memory card reader | 26 |
| • Reading a CFast 2.0 memory card | 26 |
| • Safely ejecting and removing a CFast 2.0 memory card | 26 |
| • Toolkit | 26 |
| • macOS | 26 |
| • Windows | 27 |
| CFexpress B memory card reader | 27 |
| • Reading a CFexpress B memory card | 27 |
| • Safely ejecting and removing a CFexpress B memory card | 27 |
| • Toolkit (macOS only) | 27 |
| • macOS | 28 |
| • Windows | 28 |
| 9 Expansion Port | 29 |
| DisplayPort 1.4 | 29 |
| • Connecting the DisplayPort | 29 |
| • Disconnecting the DisplayPort | 29 |

| | |
|--|-----------|
| 10 Daisy Chain and Power Delivery | 30 |
| How to daisy chain | 30 |
| Power delivery | 30 |
| 11 .Optional Formatting | 32 |
| Choosing a file system format | 32 |
| • Compatibility with both Windows and Macs | 32 |
| • Optimized performance for Windows | 32 |
| • Optimized performance for macOS | 32 |
| • Learn more | 33 |
| Formatting instructions | 33 |
| 12 .Manage RAID | 34 |
| Download and install LaCie RAID Manager | 35 |
| Launch LaCie RAID Manager | 35 |
| • Administrator users | 35 |
| • Standard users | 35 |
| Changing RAID Levels | 35 |
| LaCie RAID Manager device and app management | 35 |
| 13 .Works with iPad USB-C | 37 |
| 14 .Hard Drive Maintenance | 38 |
| Precautions | 38 |
| Replacing a hard drive | 38 |
| LaCie 2big Dock enclosure: non-serviceable components | 42 |
| 15 .Frequently Asked Questions | 43 |
| All users | 43 |
| • Problem: My file transfers are too slow. | 43 |
| • Problem: I have a USB-C hard drive that I want to add to the Thunderbolt3 daisy chain. | 43 |
| • Problem: I must password protect and/or encrypt my hard drive. | 44 |
| • Problem: I'm receiving file transfer error messages. | 44 |
| Mac | 44 |
| • Problem: The hard drive icon does not appear on my desktop | 44 |
| Windows | 45 |
| • Problem: The hard drive icon doesn't appear in Computer | 45 |
| 16 .Regulatory Compliance | 46 |
| China RoHS | 46 |
| Taiwan RoHS | 47 |

Welcome

Box content

- LaCie 2big Dock
- External power supply
- Thunderbolt 3 cable (compatible with Thunderbolt 3/USB 3.1 Gen 1/USB 3.1 Gen 2 ports)
- Quick Install Guide

Minimum system requirements

Ports

Use the included cable to connect your LaCie device to a computer with a Thunderbolt or USB-C port.

Operating system

Go to [Operating System Requirements for LaCie Hardware & Software](#).

Minimum free disk space

600MB recommended.

System Overview

Views

Front view

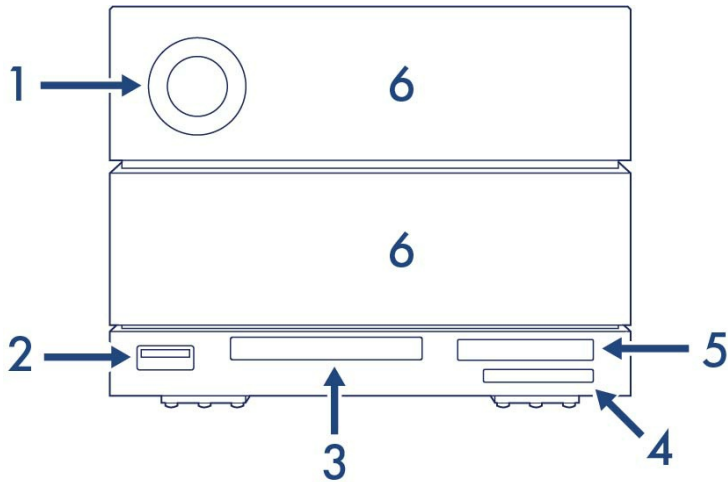

1. **Status LED**—The LED indicates that the device is powered on and provides status signals. See [Operation](#).
2. **USB 3.2 Gen 2 Hub**—Use the hub to charge devices like mobile phones (7.5W power output). Connect shuttle drives, digital cameras, and other devices to transfer files. See [Docking Features](#).
3. **CFast 2.0 Slot**—Use the slot to read CFast 2.0 memory cards. See [Docking Features](#).
4. **UHS-II SDXC Slot**—Use the slot to read SD memory cards. See [Docking Features](#).
5. **CFexpress B**—Use the slot to read CFexpress B memory cards. See [Docking Features](#).
6. **Swappable hard drive trays**—Hard drive trays can be removed to replace failed hard drives. The LaCie 2big Dock hard drives are hot-swappable. See [Hard Drive Maintenance](#).

Rear panel view

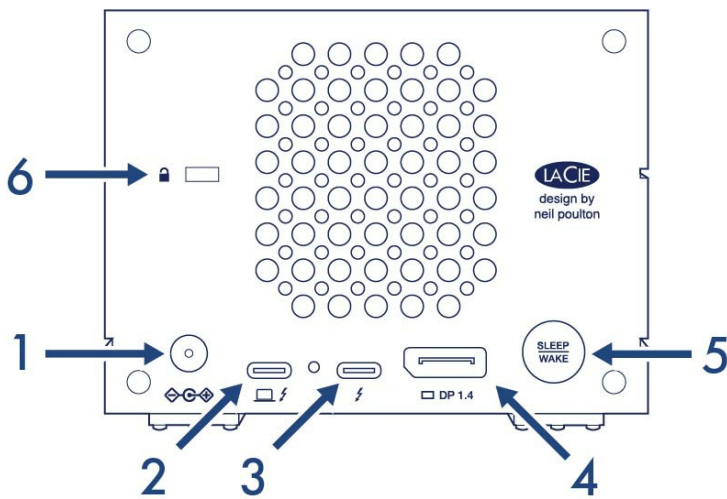

1. **Power input**—Connect the power cable to the power input port. Only use the power cable included with your LaCie 2big Dock. Attaching third-party or other LaCie power cables with incorrect voltage can damage the device. See [Operation](#).
2. **Thunderbolt 3 (host) port**—Use the provided Thunderbolt 3 cable to connect the host Thunderbolt 3 port to a Thunderbolt 3 or USB-C port on the host computer. See [Connect Your LaCie 2big Dock](#).
3. **Thunderbolt 3 (peripheral/daisy chain) port**—Connect compatible devices and displays to the peripheral/daisy chain port. You can connect a single USB device or daisy-chain multiple Thunderbolt devices. See [Daisy Chain and Power Delivery](#).
4. **DisplayPort 1.4**—Use this port to send the video signal from your computer to a monitor. You can connect a display to the DisplayPort when using the Thunderbolt 3 or USB 3.1 ports. See [Expansion Port](#).
5. **Sleep/Wake button**—Use this button to power the device off and on. The button is also used confirm key actions during RAID configuration. See [Operation](#).
6. **Kensington™ lock port**—Use this port to physically lock the 2big Dock to a desk or rack.

! **Important info regarding the ports**—The LaCie 2big Dock can be connected to one computer using the host Thunderbolt 3 port. Do not do any of the following:

- Connect both Thunderbolt 3 ports to a single computer.
- Connect a Thunderbolt 3 port to one computer and the other Thunderbolt 3 port to another computer.

Storage management

LaCie 2big Dock storage is managed by the LaCie RAID Manager software utility. See [Manage RAID](#) for more information.

Getting Started

Connect power cable

1. Connect the power supply to the power input port on LaCie 2big Dock.
2. Connect the power cord to the power supply.
3. Connect the power cord to a live power socket.

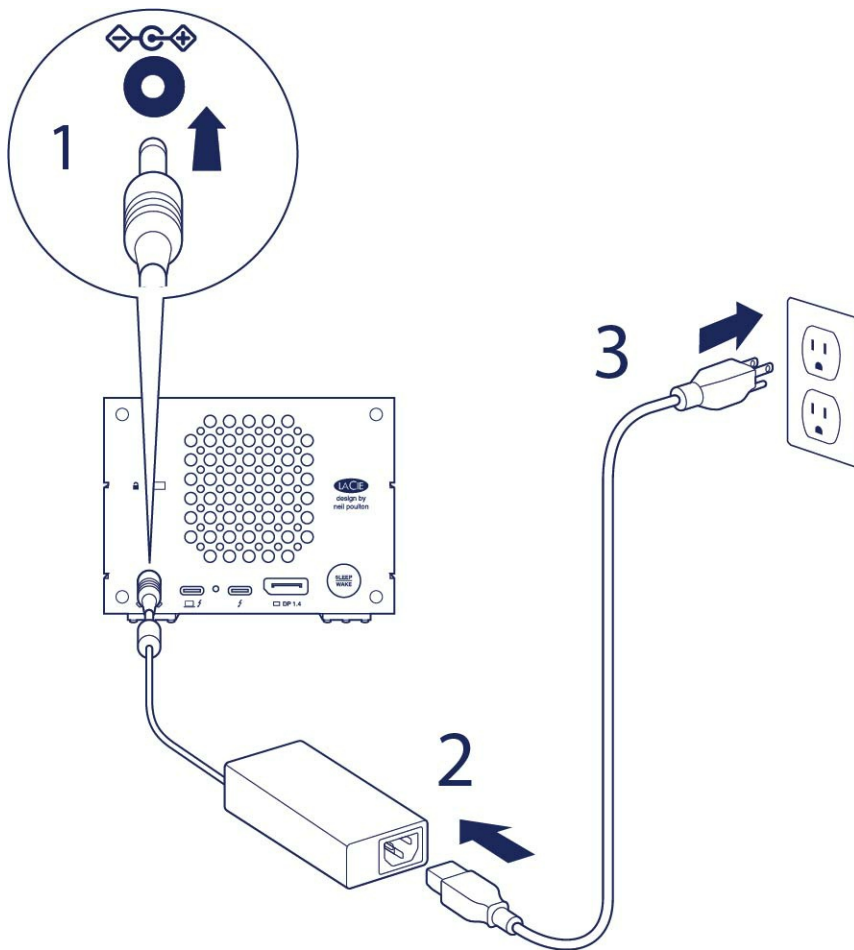

Connect to computer

The included Thunderbolt cable can be used to connect 2big Dock to USB-C host ports that support Thunderbolt or USB.

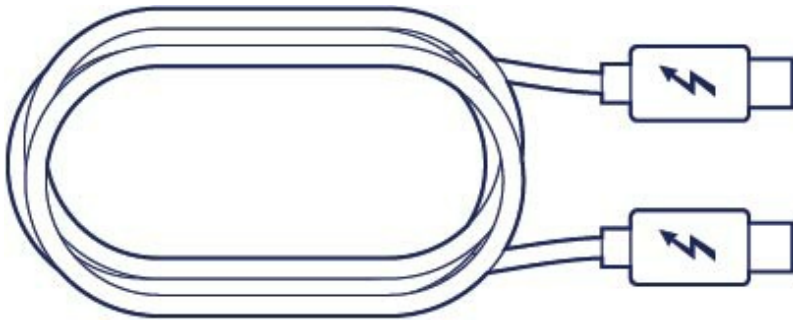

Use the Thunderbolt 3 cable to connect 2big Dock to your computer. Make sure that the cable is:

- Connected to the **host** port to the left on the back panel, and **not** the peripheral/daisy chain port.
- Connected to a USB-C port on your computer that supports Thunderbolt and/or USB.

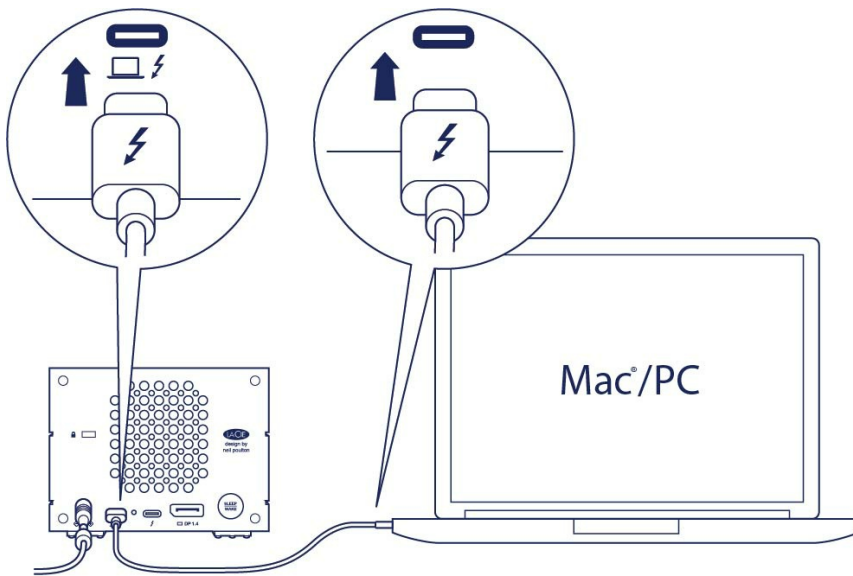

Set up LaCie 2big Dock

The setup process lets you:

Register LaCie 2big Dock

Get the most from your drive with easy access to information and support.

Install Toolkit

Manage mirror folders and backup plans, automate imports from memory cards, control LED settings, and more.



Your computer must be connected to the internet to register your device and install Toolkit.

Start here

Mac®

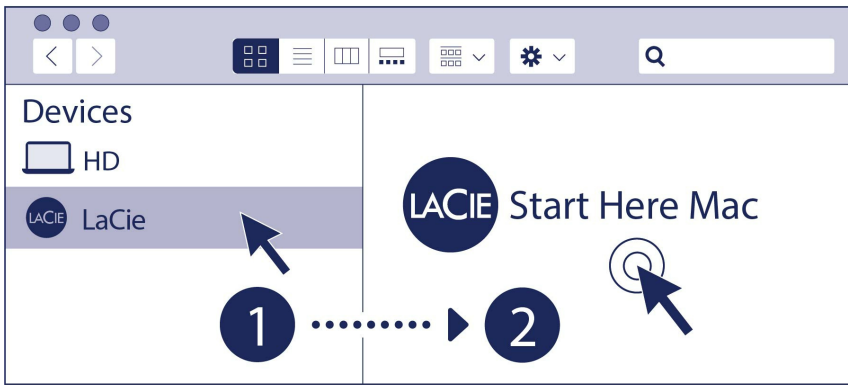

Windows®



Using a file manager such as Finder or File Explorer, open LaCie 2big Dock and launch [Start Here Mac](#) or [Start Here Win](#).

Register your device

Register

I have read and agree to...

- Terms and Conditions
- Privacy Statement
- Optional Offers

Enter your information and click [Register](#).

Download Toolkit



Click the [Download](#) button.

Install Toolkit

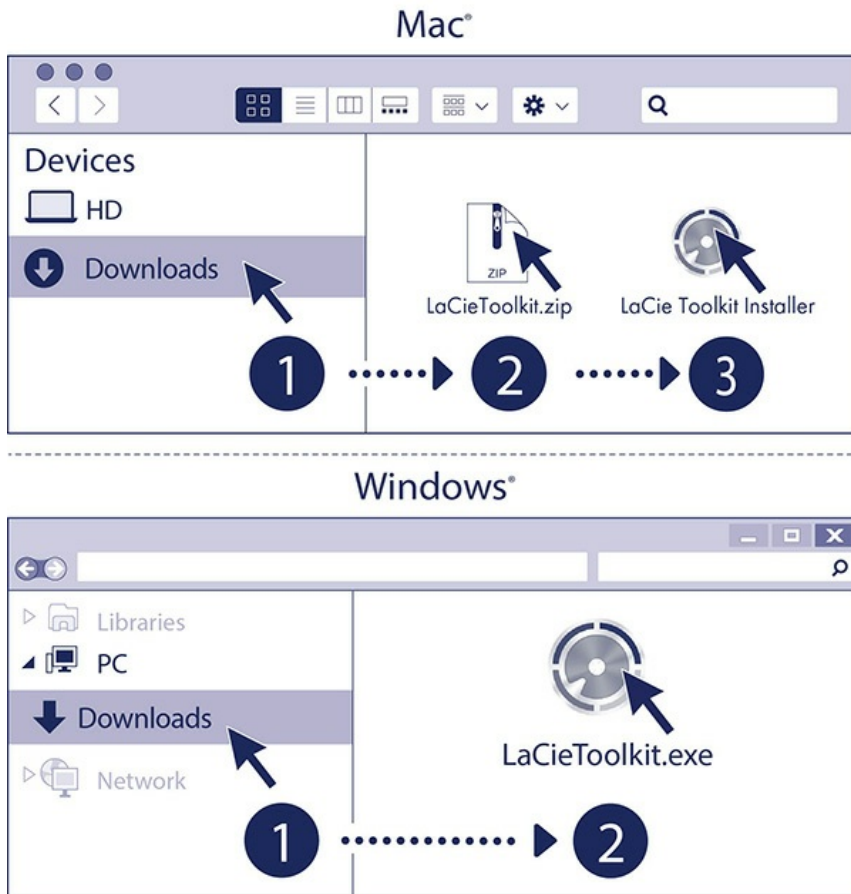

Using a file manager such as Finder or File Explorer, go to the folder where you receive downloads.



Open the [LaCieToolkit.zip](#) file. Click on the [LaCie Toolkit Installer](#) to launch the application.



Click on the [LaCieToolkit.exe](#) file to launch the application.



Your computer must be connected to the internet to install and run Toolkit.

For details on Toolkit features, see the [LaCie Toolkit user manual](#).

Storage format

2big Dock is preformatted exFAT for compatibility with both Windows and Mac computers. If you use the drive with only one type of computer, you can optimize file copy performance by formatting it in the native file system for your operating system. See [Optional Formatting and Partitioning](#) for details.

Disconnecting the drive

In order to avoid file system corruption, it's important to unmount LaCie 2big Dock's volumes before disconnecting the interface cable. See [Safely Remove From Your Computer](#) for details.

Use Toolkit to Set Up RAID, Import Files, and More

Toolkit provides useful tools that let you quickly set up RAID, import files from memory cards and USB devices, and more.

Set up a RAID array

A RAID array is a combination of two or more physical disks that are presented to the operating system as a single volume. A RAID array can optimize your storage device for performance (faster file copying) or protection (to guard against data loss). The Toolkit RAID setup wizard can guide you through choosing the right array for your storage needs.

[Click here](#) for details on RAID setups.

Automated file imports

Toolkit lets you effortlessly import files from memory cards inserted in 2big Dock's integrated card readers or from USB storage devices connected to hub port.

[Click here](#) for details on importing files.

LED controls

Use Toolkit to control the dim setting for 2big Dock's LED.

[Click here](#) for details on LED controls.

Operation

LaCie 2big Dock powers on automatically when:

- It is connected to a computer that supports Thunderbolt 3 or USB.
- It is plugged into a live power outlet.

The LEDs blink blue while the disks spin up.

! **Caution**—Do not operate LaCie 2big Dock until the ambient temperature is within the specified temperature range (see [System Overview](#)). If the hard drives have been recently installed, make sure they have time to acclimatize to the ambient temperature before operating them.

Power on

In most instances, the LaCie 2big Dock powers on automatically when connected to a computer and an active power source. However, the Sleep/Wake button can be used to power on the device if the following two conditions are met:

- The device was powered off using a long press.
- The device remains connected to the computer's USB port and an active power source.

To power on the LaCie 2big Dock, push the Sleep/Wake button for one second.

Power off

Follow the steps below to turn the device off:

1. Make certain that the device's volumes are not being accessed.
2. Eject the device's volumes from your computer's operating system.
3. Disconnect the device from your computer.

Power saving mode

Your LaCie 2big Dock can conserve energy by entering power-saving mode. The hard drives within the enclosure spin down to reduce power consumption when the 2big Dock is in power-saving mode. Power-saving mode can extend the life of the hard drives by sparing them from working during extended periods

of inactivity. The device can be put into power-saving mode using the power button:

1. Make certain that the device's volumes are not being accessed.
2. Eject the volumes from your computer's operating system.
3. Apply a short press to the Sleep/Wake button. A short press lasts no longer than 1 second.

To wake up the device, apply another short press.

Power-saving mode: daisy chain

You can daisy chain Thunderbolt technology devices when the LaCie 2big Dock is in power-saving mode. Though the hard drive spins down when the device enters power-saving mode, the Thunderbolt signal remains constant—daisy-chained devices continue data operations without interruption. See [Daisy Chain and Power Delivery](#) for details.

Power-saving mode: USB 3.2 Gen 2 hub

When LaCie 2big Dock is in power-saving mode, you can continue to browse and manage devices connected to the USB 3.2 Gen 2 hub. The connected devices continue to receive power from the 2big Dock.

Power-saving mode: managed by the PC/Mac

You can initiate power-saving mode on your computer by performing one of the following:

- Place the host computer into sleep mode.
- Mac: Go to [System Preferences | Energy Saver](#) to enable sleep mode for hard drives.
- Windows: Go to [Control Panel | Hardware | Power Options | Choose a power plan | Change advanced power settings](#). Click on [Hard disk](#) and [Turn off the hard disk after](#). Choose the time to spin down USB hard drives.

To exit power-saving mode:

| Entering power-saving mode | Exiting power-saving mode |
|--|---|
| The host computer placed the product into power-saving mode due to inactivity. | Access the device's volume on the host computer. For example, copy files to its volume. |
| The computer is in sleep mode. | Wake up the computer. |



Note on ejecting the volume and power-saving mode—The device enters power-saving mode when its volumes are ejected. To access the device's volumes, unplug the cable from the back of the device and reconnect it.

Receiving power

LaCie 2big Dock powers on automatically when it is:

- Connected directly to a computer via the Thunderbolt 3 or USB-C port. The computer must be powered on.
- Connected to a live power source via the included power supply.



Important info regarding the ports—LaCie 2big Dock can be connected to a computer using the Thunderbolt 3 host port. Do not connect both Thunderbolt ports to a single computer at the same time, or connect each Thunderbolt port to separate computers.

Short push



Important info—Always eject LaCie 2big Dock volumes from your computer before applying a short push.

A short push is a manual depression on the Sleep/Wake button that lasts no longer than one second. When the product is operating, a short push spins down the hard drives within the enclosure and initiates power-saving mode. The Thunderbolt ports remain active and are available for daisy chaining. For example, a display that is daisy chained with the device is still available to the computer following a short push.

Long push

A long push is a manual depression on the Sleep/Wake button that lasts more than four seconds. When the product is operating, a long push will cut the power to LaCie 2big Dock, forcing it to shut down immediately. A long push is not recommended for general use as it may result in data loss.

Removing the Thunderbolt cable during operation

Removing the cable during operation can result in lost data. If the cable is removed while the system is synchronizing or initializing the RAID, the synchronization/initialization continues but connection to the computer and your data is lost.

Operation and heat management

To better regulate the operating temperature, LaCie 2big Dock uses a Noctua® cooling fan to pull heat away from the internal components. In addition to being exceptionally quiet, the Noctua cooling fan is temperature controlled, which guarantees optimal heat management by adjusting the rotational speed for the environment. Additionally, the enclosure's metal casing dissipates heat from the hard drives, keeping them

safe and prolonging their life. Since LaCie's unique design draws heat away from the internal hard drives, the external casing may be warm to the touch after extended use.

i **Important info**—The wide exhaust chamber on the rear of LaCie 2big Dock allows for enhanced airflow. Make sure that it is not obstructed and that there is a natural airflow across the casing.

Position

Always make certain to place LaCie 2big Dock on a flat, even surface designed to support the heat output and airflow of a professional hard disk enclosure. For proper heat dissipation, LaCie 2big Dock is designed to stand on its rubber feet, situated on the bottom of the enclosure. Do **not** place the enclosure on its side when it is powered on.

System LEDs

LED locations

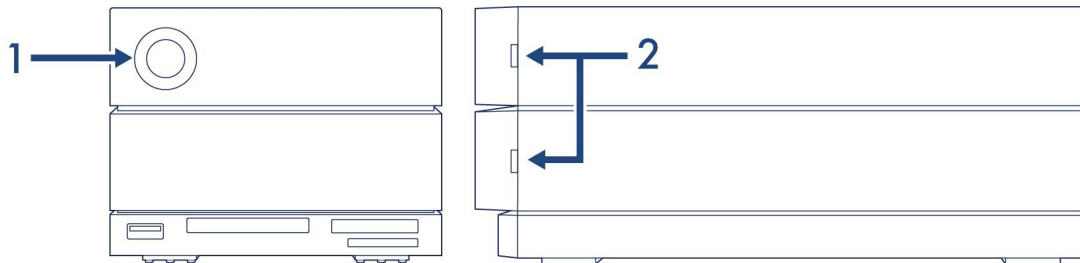

1. **Front**—System status
2. **Side**—Hard drive status

LED behavior

The list of colors below helps you identify the general status of your LaCie 2big Dock.

| Color | State |
|--|--|
| Solid blue | Ready |
| Blinking blue | Activity |
| Slow blinking blue (10 second interval) | Power-saving |
| Fast blinking blue | Startup and shutdown |
| Blinking red and blue | RAID initialization or synchronization |
| Blinking red (1 second interval) | Temperature warning or fan failure |
| Solid red | Temperature critical or fan absent |

i LEDs for this device can be dimmed using the Toolkit app. See the [LaCie Toolkit user manual](#) for details.

Safely Remove Device From Your Computer

Always eject a storage drive from your computer before physically disconnecting it. Your computer must perform filing and housekeeping operations on the drive before it is removed. Therefore, if you unplug the drive without using the operating system's software, your files can become corrupt or damaged.

Windows

Use the Safely Remove tool to eject a device.

1. Click the Safely Remove Hardware icon in your Windows System Tray to view the devices you can eject.
2. If you don't see the Safely Remove Hardware icon, click the Show hidden icons arrow in the system tray to display all icons in the notification area.
3. In the list of devices, choose the device you want to eject. Windows displays a notification when it is safe to remove the device.
4. Disconnect the device from the computer.

Mac

There are several ways you can eject your device from a Mac. See below for two options.

Eject via Finder window

1. Open a Finder window.
2. On the sidebar, go to Devices and locate the drive you want to eject. Click the eject symbol to the right of the drive name.
3. Once the device disappears from the sidebar or, the Finder window closes, you can disconnect the interface cable from your Mac.

Eject via Desktop

1. Select the desktop icon for your device and drag it to the Trash.
2. When the device icon is no longer visible on your desktop, you can physically disconnect the device from your Mac.

Docking Features

LaCie 2big Dock provides you with convenient means of managing your digital content. Insert Secure Digital, CFast 2.0, and CFexpress B cards to transfer files for safe storage. Connect smartphones, cameras, and other devices to the USB 3.2 Gen 2 hub to access content.

USB 3.2 Gen 2

Use the hub to transfer files from digital cameras and other drives. The USB 3.2 Gen 2 hub port delivers 7.5W of power to connected phones and other devices.

Connecting a device to the USB 3.2 hub

1. Hold the USB-A end of the cable upright.
2. Insert the cable end into the USB 3.2 port on the front of the device.

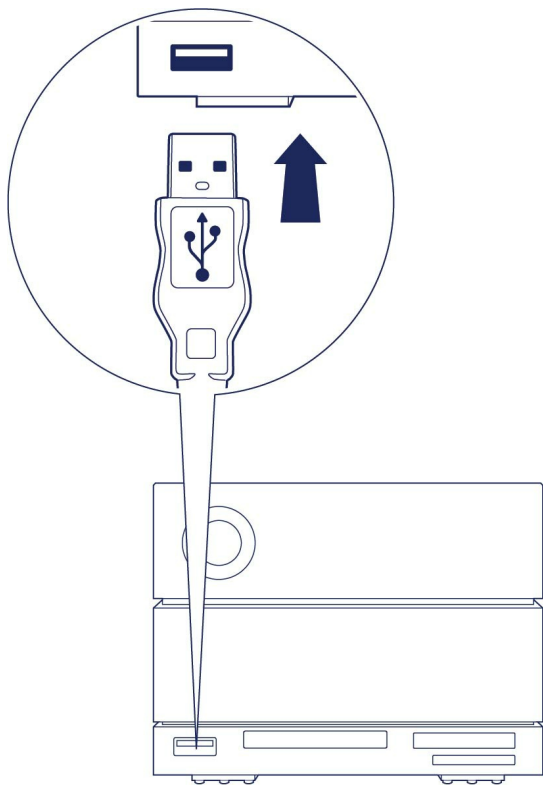

3. Open a Finder or File Explorer window to browse and manage the contents of the device.

Safely ejecting and disconnecting a device from the USB 3.2 hub

macOS

1. Make sure that the device is not being accessed.
2. Using a Finder window, eject the device volume.
3. Remove the USB-A end of the cable from the port.

Windows

1. Click the Safely Remove icon in your Windows System Tray to view the devices you can eject. If you don't see the Safely Remove Hardware icon, click the Show Hidden Icons arrow in the system tray to display all icons in the notification area.
2. In the list of devices, choose the storage device you want to eject. Windows displays a notification when it is safe to remove the device.
3. Remove the USB-A end of the cable from the port.

Secure Digital Extended Capacity (SDXC) memory card reader



The port supports up to SD UHS II.

Reading an SD memory card

1. Hold your SD, SDHC, or SDXC memory card upright with the label on top (pins on bottom).
2. Insert the card into the SD slot on the front of the device as far as it will go (you may hear an audible 'click'), and then release. The card is now locked in the slot.

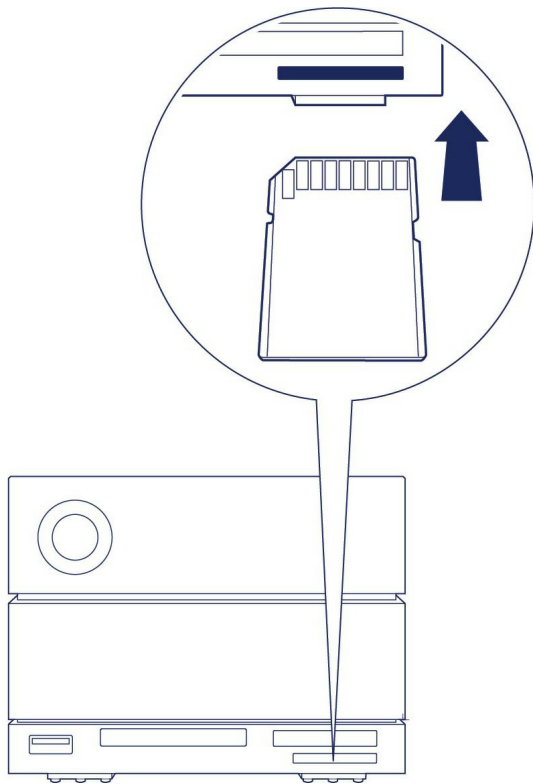

3. Open a Finder or File Explorer window to browse and manage the contents of the SD card.

Safely ejecting and removing an SD memory card

Toolkit

1. Make sure that the SD memory card is not being accessed.
2. Open Toolkit.
3. On the Home screen, click on the Eject icon for the SD card slot.
4. Push the card into the SD slot on the front of the device as far as it will go (you may hear an audible 'click'), and then release. The card is ejected.
5. Remove the card from the slot.

macOS

1. Make sure that the SD memory card is not being accessed.
2. Using a Finder window, eject the SD card volume.
3. Push the card into the SD slot on the front of the device as far as it will go (you may hear an audible 'click'), and then release. The card is ejected.
4. Remove the card from the slot.

Windows

1. Click the Safely Remove icon in your Windows System Tray to view the devices you can eject. If you don't see the Safely Remove Hardware icon, click the Show Hidden Icons arrow in the system tray to display all icons in the notification area.
2. In the list of devices, choose the SD card volume you want to eject. Windows displays a notification

when it is safe to remove the device.

3. Push the card into the SD slot on the front of the device as far as it will go (you may hear an audible 'click'), and then release. The card is ejected.
4. Remove the card from the slot.

CFast 2.0 memory card reader

Reading a CFast 2.0 memory card

1. Hold your CFast 2.0 memory card upright with the label on top.
2. Insert the card into the CFast 2.0 slot on the front of the device and gently push it in until it's seated in the slot.

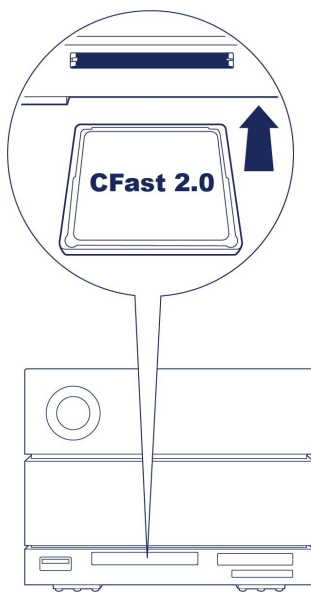

3. Open a Finder or File Explorer window to browse and manage the contents of the CFast 2.0 card.

Safely ejecting and removing a CFast 2.0 memory card

Toolkit

1. Make sure that the CFast 2.0 memory card is not being accessed.
2. Open Toolkit.
3. On the Home screen, click on the Eject icon for the CFast 2.0 card slot.
4. Remove the card from the slot.

macOS

1. Make sure that the CFast 2.0 memory card is not being accessed.
2. Using a Finder window, eject the CFast 2.0 card volume.
3. Remove the card from the slot.

Windows

1. Click the Safely Remove icon in your Windows System Tray to view the devices you can eject. If you don't see the Safely Remove Hardware icon, click the Show Hidden Icons arrow in the system tray to display all icons in the notification area.
2. In the list of devices, choose the CFast 2.0 card volume you want to eject. Windows displays a notification when it is safe to remove the device.
3. Remove the card from the slot.

CFexpress B memory card reader

Reading a CFexpress B memory card

1. Hold your CFexpress B memory card upright with the label on top.
2. Insert the card into the CFexpress B slot on the front of the device and gently push it in until it's seated in the slot.

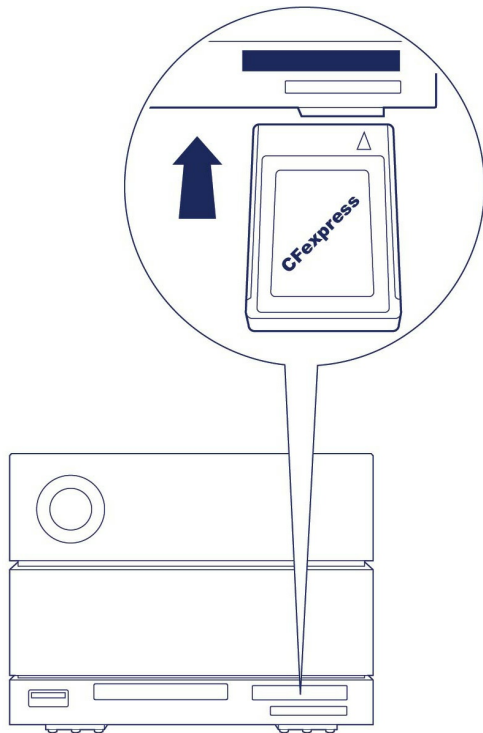

3. Open a Finder or File Explorer window to browse and manage the contents of the CFexpress B card.



Important—LaCie 2big Dock supports CFexpress B but not XQD media card format.

Safely ejecting and removing a CFexpress B memory card

Toolkit (macOS only)

1. Make sure that the CFexpress B memory card is not being accessed.
2. Open Toolkit.
3. On the Home screen, click on the Eject icon for the CFexpress B card slot.
4. Remove the card from the slot.

macOS

1. Make sure that the CFexpress B memory card is not being accessed.
2. Using a Finder window, eject the CFexpress B card volume.
3. Remove the card from the slot.

Windows

In order to maximize copy performance, Windows treats a card inserted in the CFexpress B slot as a non-removable drive. To safely remove a CFexpress B card with reduced risk of data loss, eject LaCie 2big Dock from your computer before physically withdrawing the card from the slot.

1. Make sure that inserted memory cards are not being accessed.
2. Make sure that LaCie 2big Dock is not being accessed.
3. Click the Safely Remove icon in your Windows System Tray to view the devices you can eject. If you don't see the Safely Remove Hardware icon, click the Show Hidden Icons arrow in the system tray to display all icons in the notification area.
4. In the list of devices, choose LaCie 2big Dock to eject. Windows displays a notification when it is safe to disconnect the device.
5. Disconnect the Thunderbolt cable from the PC and wait for 2big Dock to power down.
6. Remove the CFexpress B card from the slot.
7. Reconnect the Thunderbolt cable to power on 2big Dock.

Expansion Port

DisplayPort 1.4

DisplayPort is a digital display interface used to connect a video source to a display device (for example, a computer monitor) as well as other forms of digital data. DP 1.4 supports up to two 4K displays or one 8K display.

i LaCie 2big Dock provides the full performance available to DisplayPort 1.4. However, not all computers with Thunderbolt ports support DisplayPort 1.4, which limits the outputs to displays. In addition, some displays do not accept the full bandwidth available to DisplayPort 1.4. Check the documentation for your computers and displays for DisplayPort 1.4 compatibility.

i DisplayPort may be compatible with some HDMI, DVI, and VGA adapters (not included). Note that these have not been tested.

Connecting the DisplayPort

1. Insert the DP 1.4 end of the cable or adapter into the port on the back of the 2big Dock until it clicks into place. The cable/adapter is now locked into the DP 1.4 port.
2. Connect the other end of the cable to your configured audio/video display.

Disconnecting the DisplayPort

1. Grasp the DP 1.4 end of the cable or adapter that's connected to 2big Dock.
2. Hold down the release tab with your thumb, and then pull back to remove the cable from the port.

Daisy Chain and Power Delivery

Use the two Thunderbolt 3 ports on the LaCie 2big Dock for:

- Direct connection to a computer that is compatible with Thunderbolt 3 and Thunderbolt 4 technology.
- Daisy chaining with devices and displays that are compatible with Thunderbolt technology.

How to daisy chain

The peripheral Thunderbolt 3 port on 2big Dock can be used to daisy chain compatible Thunderbolt peripherals, such as hard drives and monitors. If you have another Thunderbolt storage device, make certain to connect it to the daisy chain before adding compatible displays or USB devices. See below for an example of the order of devices in a Thunderbolt daisy chain.

1. Computer with a Thunderbolt 3 port.
2. LaCie 2big Dock (connected to computer via **host** Thunderbolt 3 port).
3. LaCie d2 Thunderbolt 3 (connected to 2big Dock's **peripheral/daisy chain** Thunderbolt 3 port).
4. Second LaCie d2 Thunderbolt 3 (connected to first d2 via Thunderbolt 3 port).
5. LaCie Rugged SSD (connected to second d2 via Thunderbolt 3 port).

USB devices can terminate a Thunderbolt daisy chain and should always be the last device. It must be connected to the secondary Thunderbolt port on the preceding device. (The USB device will not be recognized if connected to the preceding device's USB-C port.)

i **Important cable info:** When connecting 2big Dock's peripheral/daisy chain Thunderbolt 3 port to a compatible device, use cables specifically constructed to support Thunderbolt 3.

Power delivery

2big Dock delivers power to your connected laptop and compatible peripheral devices.

| No device connected to peripheral port | |
|--|-----------------|
| Host port | Peripheral port |
| 45W | - |

Device connected to peripheral port

| Host port | Peripheral port |
|-----------|-----------------|
|-----------|-----------------|

| | |
|-----|-----|
| 30W | 15W |
|-----|-----|



2big Dock must receive power via its power cable in order to deliver power to compatible devices.



LaCie is not responsible for devices that experience harm, damage, or malfunction when connected to LaCie 2big Dock.

Optional Formatting

Your device is preformatted exFAT (Extended File Allocation Table) for compatibility with both Mac and Windows computers.

Choosing a file system format

When choosing a file system format, consider whether **compatibility** or **performance** is more important in your everyday use of the drive.

- **Compatibility**—You need a cross-platform format because you connect your drive to both PCs and Macs.
- **Performance**—You connect your drive with only one type of computer, so you can optimize file copy performance by formatting the drive in the native file system for your computer operating system.

Compatibility with both Windows and Macs

exFAT is a lightweight file system compatible with all versions of Windows and modern versions of macOS. If you use your drive with both PCs and Macs, format your drive in exFAT. While exFAT offers cross-platform access to both computers, keep in mind the following:

- exFAT is not compatible or recommended for built-in backup utilities such as File History (Windows) and Time Machine (macOS). If you want to use one of these backup utilities, you should format the drive in the native file system for the computer running the utility.
- exFAT is not a journaled file system, which means it can be more susceptible to data corruption when errors occur or the drive is not disconnected properly from the computer.

Optimized performance for Windows

NTFS (New Technology File System) is a proprietary journaling file system for Windows. macOS can read NTFS volumes, but it can't natively write to them. This means your Mac can copy files from an NTFS-formatted drive, but it can't add files to or remove files from the drive. If you need more versatility than this one-way transfer with Macs, consider exFAT.

Optimized performance for macOS

Apple offers two proprietary file systems.

Mac OS Extended (also known as Hierarchical File System Plus or HFS+) is an Apple file system used since 1998 for mechanical and hybrid internal drives. macOS Sierra (version 10.12) and earlier use HFS+ by

default.

APFS (Apple File System) is an Apple file system optimized for solid state drives (SSDs) and flash-based storage systems, though it also works with hard disk drives (HDDs). It was first introduced with the release of macOS High Sierra (version 10.13). APFS can only be read by Macs running High Sierra or later.

When choosing between Apple file systems, consider the following:

- Windows cannot natively read or write to APFS or HFS+ volumes. If you need cross-platform compatibility, you should format the drive in exFAT.
- If you intend to use your drive with Time Machine:
 - The default format for macOS Big Sur (version 11) and later is APFS.
 - The default format for macOS Catalina (version 10.15) and earlier is HFS+.
- If you intend to use your drive to move files between Macs running older OS versions, consider formatting your drive in HFS+ rather than APFS.
- macOS file systems and Android: Formatting your drive for macOS may not be supported with connections to Android mobile devices.

Learn more

For additional considerations when choosing a file system format, see [File System Format Comparisons](#).

Formatting instructions

For instructions on formatting your drive, see [How to format your drive](#).

Manage RAID

RAID stands for redundant array of independent disks. RAID contains the word array, and the two terms are often used interchangeably. An array is a combination of two or more physical disks that are presented to the operating system as a single volume.

Disks are combined into different RAID configurations known as RAID levels. The RAID level you choose depends on which storage attributes are most important to you:

| | |
|--------------------|--|
| Capacity | The total amount of data you can store. |
| Performance | The speed at which data is copied. |
| Protection | The number of disks that can fail before data is lost. |

Your LaCie 2big Dock can be configured as RAID 0, RAID 1, or JBOD. Each RAID level has its own advantages:

RAID 0—Data is not duplicated on both hard drives in RAID 0. This results in faster transfers and more storage, since the full capacity of both drives can be used to store unique data. However, RAID 0 lacks a very important feature: data protection. If a hard drive fails, all data in the array is lost.

RAID 1—RAID 1 provides greater safety since data is duplicated on each disk in the array. If a single disk fails, the data remains available on the other disk. However, this comes at a cost—since the same data is written to each drive, copying data takes longer and overall storage capacity is reduced by 50%. RAID 1 is a good choice when safety is more important than speed or disk space.

JBOD—“JBOD” stands for “Just a Bunch of Disks”, meaning that your two drives have not been configured as an array and operate as two independent disks.

To summarize, each RAID level has its own advantages:

| RAID level | Capacity | Protection | Speed | Factory default |
|------------|----------|------------|-----------|-----------------|
| RAID 0 | 100% | None | Excellent | Yes |
| RAID 1 | 50% | Excellent | Good | No |
| JBOD | 100% | None | Varies | No |

Download and install LaCie RAID Manager

LaCie RAID Manager manages the storage for your LaCie storage device. Download and install LaCie RAID Manager before connecting the LaCie storage device to your computer. The process automatically installs a driver that allows LaCie RAID Manager to detect the device and manage RAID arrays. For download instructions, see the [LaCie RAID Manager for 2-Bay Devices user manual](#).

Learn more about LaCie RAID Manager

[LaCie RAID Manager for 2-Bay Devices](#)
[Download LaCie RAID Manager](#)
[Supported operating systems](#)

Launch LaCie RAID Manager

Administrator users

Users with administrator privileges for the computer can launch LaCie RAID Manager without signing into the application.

Standard users

A standard (non-administrator) user launching LaCie RAID Manager is prompted to sign in with administrator credentials. An administrator should launch the application to prepare the device for a standard user.

Changing RAID Levels

To change RAID levels, confirm that 2big Dock is connected to your computer and powered.

! All files are deleted from 2big Dock when you modify the array.

1. Launch LaCie RAID Manager.
2. Click [Array](#) in the sidebar, and then click Modify.
3. Choose the RAID level you want to configure and click Next.
4. Confirm that you want to modify the array by clicking Modify.
5. Follow the onscreen prompts.

LaCie RAID Manager device and app management

For other LaCie RAID Manager functions, see the [LaCie RAID Manager for 2-Bay Devices user manual](#).

Works with iPad USB-C

Your LaCie storage devices can be used with higher-end iPads. This is a great option for moving files between computers, cloud services and external storage. The iPad is also a perfect mobile editing station for importing media to more advanced imaging and video apps.

See [External Storage and iPadOS](#) for details on the following:

- Connecting Storage to Compatible iPads
- Available Actions
- Selecting Multiple Items
- Accessing Storage Devices in an App
- Supported External Storage Devices and USB Hubs
- External Storage Performance on iPad Versus a Computer
- Thunderbolt Storage Devices
- Battery Use
- Ejecting
- Storage Formats
- Password Protection
- Toolkit and First Use Connections

Hard Drive Maintenance

Precautions

- “Hot-swapping” means that you can remove and replace hard drives while the enclosure is powered on.
- During operation, the hard drives should remain in their slots for optimal air flow. Airflow and fan performance are regulated by temperature.
- Observe all conventional ESD precautions when handling hard drives.

Replacing a hard drive

If a failed hard drive is under warranty, make certain to contact LaCie support to receive a replacement disk.

It's not necessary to power down the device to replace a single hard drive.

1. Locate the hard drive you want to replace and place your index finger on the small hole on the right side of its disk tray.

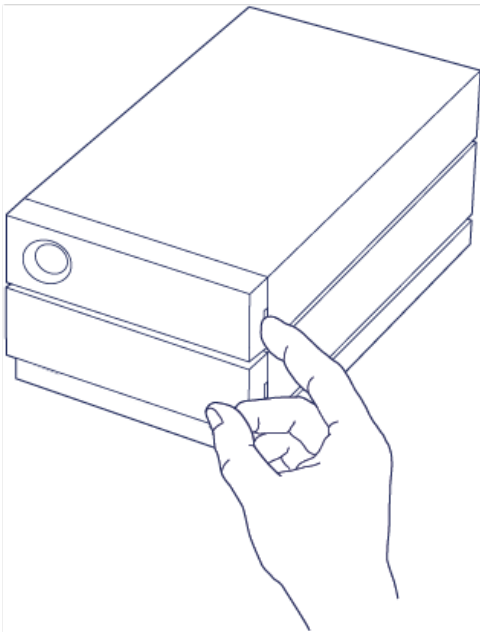

2. Gently pull your index finger away from the enclosure and maintain a firm grip as it unlocks the hard drive from the SATA connector. Once it is loose, hold the hard drive with both hands as you remove it from the slot.

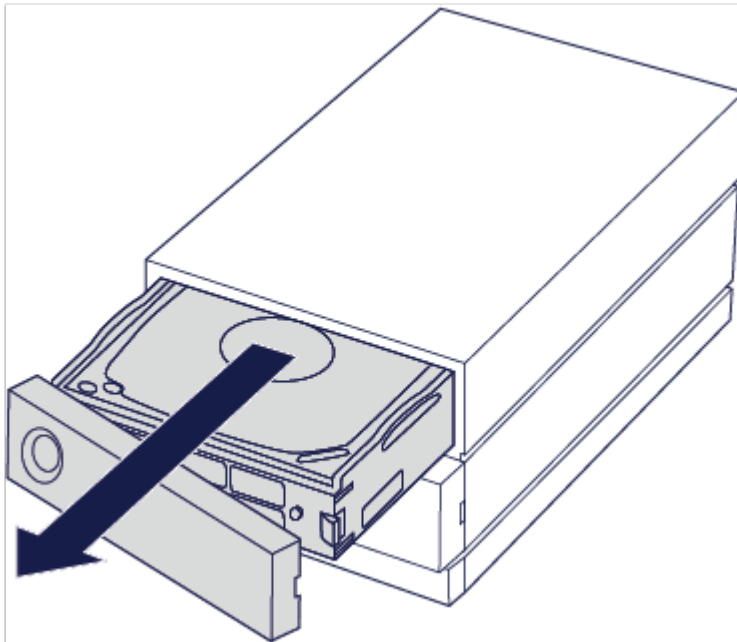
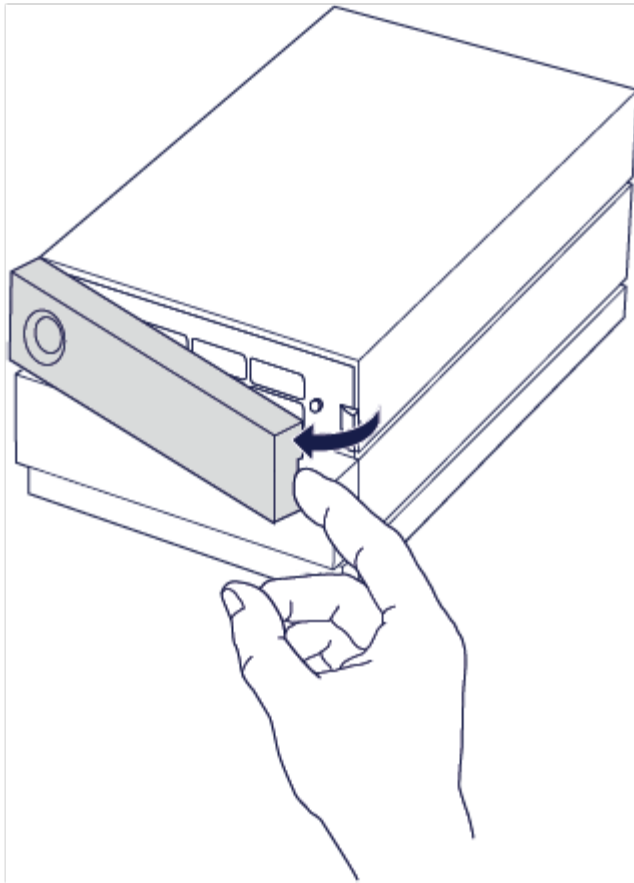

3. If you are replacing a failed hard drive with a full disk tray, skip to Step 4. Continue here if you are replacing the hard drive using the same disk tray.
 - Using a Phillips head screwdriver, carefully unfasten all four screws from their four slots.

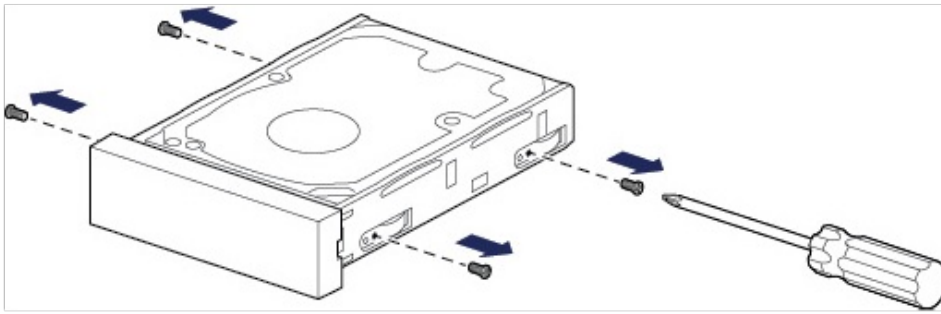

- Gently slide the disk out of the tray.

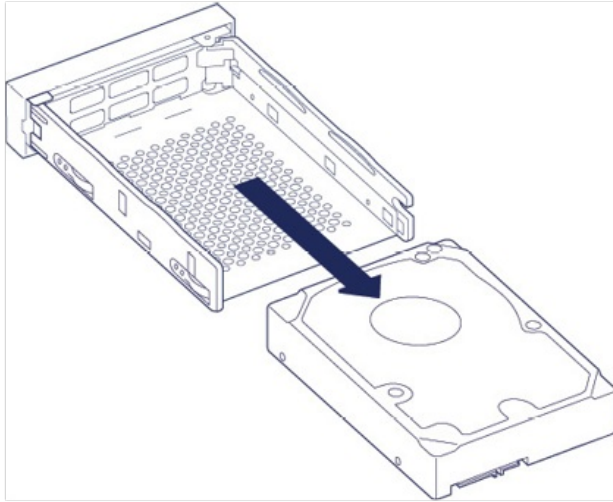

- Place the empty disk tray onto a flat work area with the handle on the bottom left.
- Many disks have a label on one side and the printed circuit board on the opposite side. With its label side facing up, gently place the hard disk within the disk tray. Ensure the SATA connector is on the left. The four screw slots should align with the disk's four screw holes.

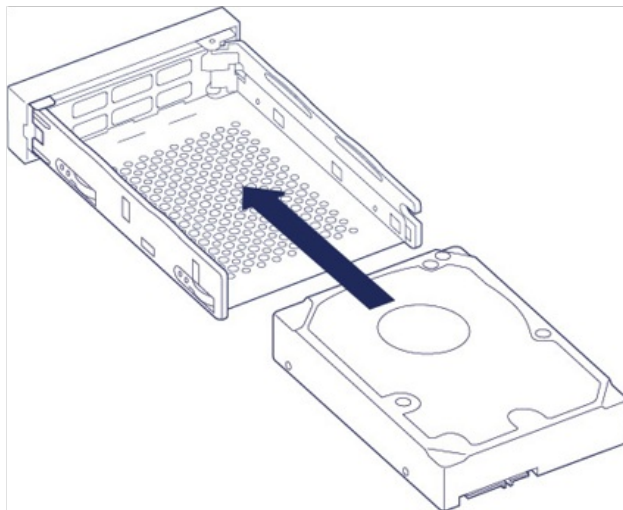

4. Using a Phillips head screwdriver, carefully fasten all four screws into their four slots. Do not force the screws into the slots. Forcing the screws too tight into the slots can make it difficult to remove them later and strip the screws' teeth.

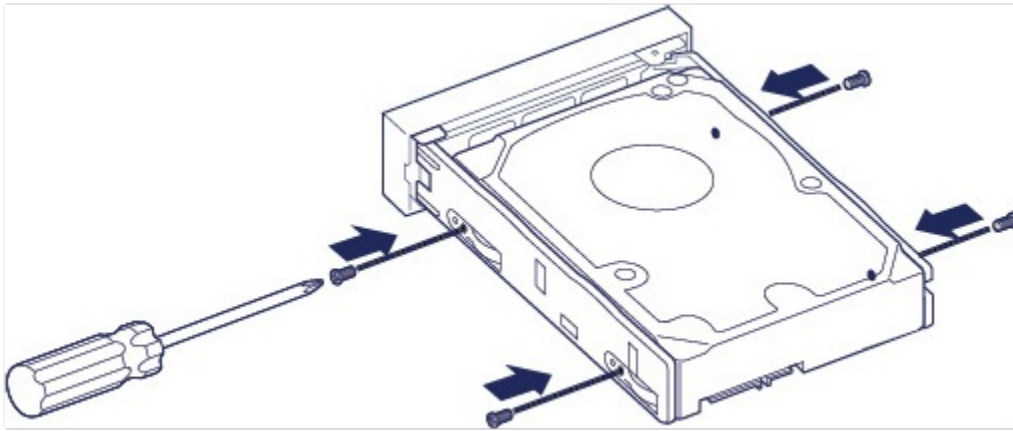

5. Carefully insert the full disk tray into the empty disk slot. Gently push the disk tray handle until you feel it snap into place.

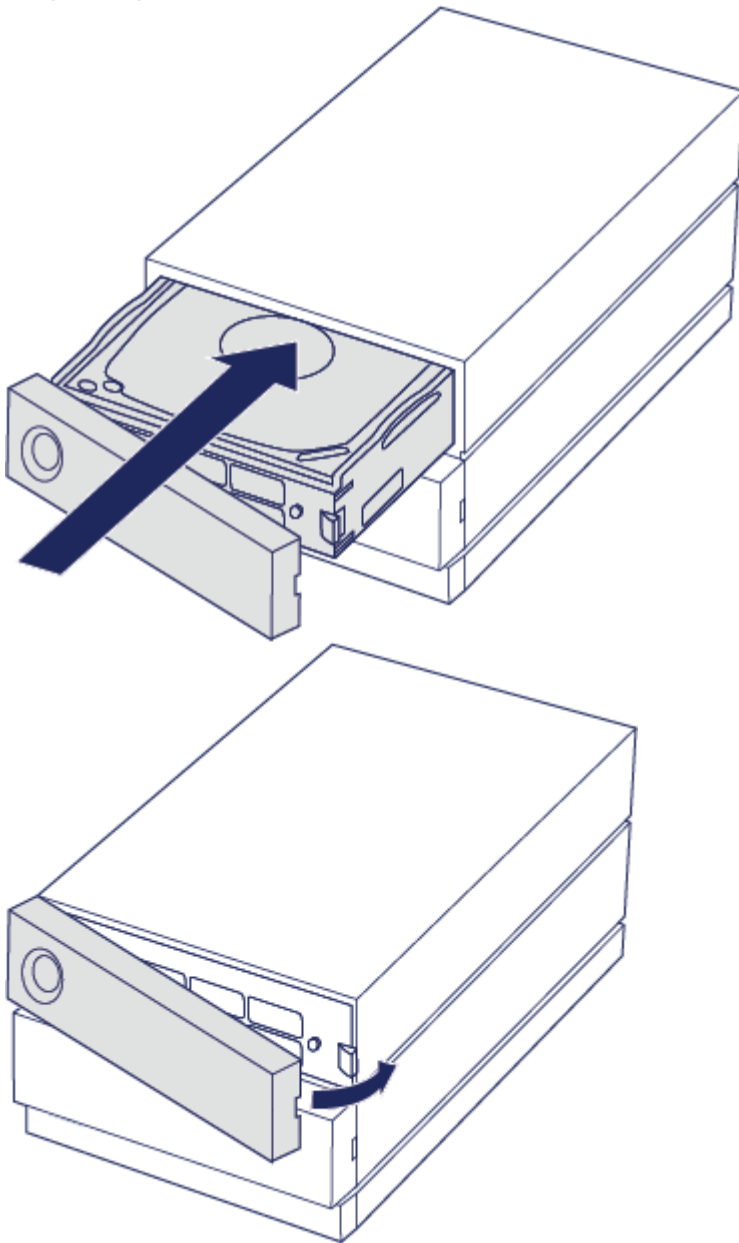

When replacing hard drives that are members of an active RAID array, the hard drive LEDs blink red and blue indicating that the RAID is synchronizing data. You can continue to use LaCie 2big Dock storage but

performance is reduced until the synchronization is complete.

LaCie 2big Dock enclosure: non-serviceable components

The components inside the chassis are NOT hot-swappable and are NOT serviceable at any location outside of LaCie-approved service centers. Removing the cover voids your product's warranty. Additionally, removing, replacing or changing any part in the enclosure or, performing any action that involves the components in the enclosure, voids the product's warranty. If you are experiencing hardware errors or failure, contact LaCie support for assistance.

Frequently Asked Questions

For help setting up and using your LaCie hard drive, review the frequently asked questions below. For additional support resources, go to www.lacie.com/support/2big-dock.

All users

Problem: My file transfers are too slow.

Thunderbolt 3

Q: Are both ends of the cable firmly attached?

A: Review troubleshooting tips for cable connections below:

- Check both ends of the cable and make sure they are fully seated in their respective ports.
- Try safely ejecting LaCie 2big Dock from your computer and then disconnect the cable. Wait 10 seconds and then reconnect 2big Dock to the computer.

Q: Are there other Thunderbolt 3 or USB devices connected to the same port or hub?

A: Disconnect other devices and see if the drive's performance improves.

Q: Is the device connected to a Thunderbolt 3 USB-C port on your computer or hub?

A: Connect 2big Dock to a USB-C port on your computer that supports Thunderbolt 3 or Thunderbolt 4 devices. The lightning bolt icon that represents Thunderbolt 3 support should appear next to the USB-C port.

Q: Does your computer or operating system support Thunderbolt 3?

A: Consult your computer and operating system documentation for Thunderbolt 3 compatibility information.

Problem: I have a USB-C hard drive that I want to add to the Thunderbolt 3 daisy chain.

Q: Can I attach my USB-C hard drive to a Thunderbolt 3 daisy chain?

A: Yes. Make certain to add the USB-C hard drive to the end of a Thunderbolt 3 daisy chain since USB devices do not include a second port to continue the chain. Please note that USB-C devices do not become Thunderbolt 3 devices when added to a Thunderbolt 3 daisy chain. The USB-C device can only provide performance within its potential. For example, a USB 3.1 Gen 1 hard drive added to the end of a Thunderbolt 3 daisy chain can reach up to 5Gb/s while a USB 3.1 Gen 2 hard drive can reach up to 10Gb/s.

Problem: I must password protect and/or encrypt my hard drive.

Q: Can I password protect my hard drive?

A: Yes, it is possible to protect the hard drive or individual folders and files with a password. There are many third-party solutions for password protection. However, LaCie cannot guarantee them since we do not test third-party applications.

Some versions of Windows have a built-in utility called Bitlocker that can protect hard drives with a password. For more information about Bitlocker, consult [Microsoft's support documentation](#).

Q: Can I encrypt my hard drive?

A: Yes, the hard drive can be encrypted. There are many third-party solutions for encryption. However, LaCie cannot guarantee them since we do not test third-party applications.

Some versions of Windows have a built-in utility called Bitlocker that can encrypt hard drives. For more information about Bitlocker, consult [Microsoft's support documentation](#)

Problem: I'm receiving file transfer error messages.

Q: Did you get an "Error -50" message while copying to a FAT32 volume?

A: When copying files or folders from a computer to a FAT32 volume, certain characters in the names cannot be copied. These characters include, but are not limited to: ? < > / \ :

Check your files and folders to ensure that these characters are not in the names.

If this is a recurring problem or you cannot find files with incompatible characters, consider reformatting the drive to NTFS (Windows users) or HFS+ (Mac users). See [Optional Formatting and Partitioning](#).

Mac

Problem: The hard drive icon does not appear on my desktop

Q: Is your Finder configured to hide hard drives on the desktop?

A: Go to Finder and then check [Preferences | General tab | Show these items on the desktop](#). Confirm that [Hard Disks](#) is selected.

Q: Is your hard drive mounting in the operating system?

A: Open Disk Utility at [Go | Utilities > | Disk Utility](#). If the hard drive is listed in the left-hand column, check your Finder preferences to see why it is not displayed on the desktop (review the question above).

Q: Did you follow the correct installation steps for your operating system?

A: Review the installation steps in [Getting Connected](#).

Windows

Problem: The hard drive icon doesn't appear in Computer

Q: Is the hard drive listed in Device Manager?

A: All drives appear in at least one place in Device Manager.

Type `Device Manager` in Search to launch it. Look in the Disk Drives section and, if necessary, click the Plus (+) icon to view the full list of devices. If you're uncertain that your drive is listed, safely unplug it and then reconnect it. The entry that changes is your LaCie hard drive.

Q: Is your hard drive listed next to an unusual icon?

A: Windows Device Manager usually provides information about failures with peripherals. While the Device Manager can assist with troubleshooting most problems, it may not display the exact cause or provide a precise solution.

An unusual icon next to the hard drive can reveal a problem. For example, instead of the normal icon based on the type of device, it has an exclamation point, question mark or an X. Right click this icon and then choose Properties. The General tab provides a potential reason why the device is not working as expected.

Regulatory Compliance

| | |
|--------------|-----------------|
| Product Name | LaCie 2big Dock |
|--------------|-----------------|

| | |
|-------------------------|---------|
| Regulatory Model Number | LRDMU06 |
|-------------------------|---------|

China RoHS



China RoHS 2 refers to the Ministry of Industry and Information Technology Order No. 32, effective July 1, 2016, titled Management Methods for the Restriction of the Use of Hazardous Substances in Electrical and Electronic Products. To comply with China RoHS 2, we determined this product's Environmental Protection Use Period (EPUP) to be 20 years in accordance with the Marking for the Restricted Use of Hazardous Substances in Electronic and Electrical Products, SJT 11364-2014.

中国 RoHS 2 是指 2016 年 7 月 1 日起施行的工业和信息化部令第 32 号“电力电子产品限制使用有害物质管理办法”。为了符合中国 RoHS 2 的要求，我们根据“电子电气产品有害物质限制使用标识”(SJT 11364-2014) 确定本产品的环保使用期 (EPUP) 为 20 年。

| 部件名称 Part Name | 有害物质 Hazardous Substances | | | | | |
|---|------------------------------|-----------|-----------|----------------------------|---------------|-----------------|
| | 铅 (Pb) | 汞 (Hg) | 镉 (Cd) | 六价铬 (Cr ⁶⁺) | 多溴联苯 (PBB) | 多溴二苯醚 (PBDE) |
| 硬盘驱动器 HDD | X | O | O | O | O | O |
| 外接硬盘印刷电路板 Bridge PCBA | X | O | O | O | O | O |
| 电源(如果提供) Power Supply (if provided) | X | O | O | O | O | O |
| 接口电缆(如果提供) Interface cable (if provided) | X | O | O | O | O | O |
| 其他外壳组件 Other enclosure components | O | O | O | O | O | O |

本表格依据 SJ/T 11364 的规定编制。
This table is prepared in accordance with the provisions of SJ/T 11364-2014

O: 表示该有害物质在该部件所有均质材料中的含量均在 GB/T 26572 规定的限量要求以下。
O: Indicates that the hazardous substance contained in all of the homogeneous materials for this part is below the limit requirement of GB/T26572.

X: 表示该有害物质至少在该部件的某一均质材料中的含量超出 GB/T 26572 规定的限量要求。
X: Indicates that the hazardous substance contained in at least one of the homogeneous materials used for this part is above the limit requirement of GB/T26572.

Taiwan RoHS

Taiwan RoHS refers to the Taiwan Bureau of Standards, Metrology and Inspection's (BSMI's) requirements in standard CNS 15663, Guidance to reduction of the restricted chemical substances in electrical and electronic equipment. Beginning on January 1, 2018, Seagate products must comply with the "Marking of presence" requirements in Section 5 of CNS 15663. This product is Taiwan RoHS compliant. The following table meets the Section 5 "Marking of presence" requirements.

台灣RoHS是指台灣標準局計量檢驗局(BSMI)對標準CNS15663要求的減排電子電氣設備限用化學物質指引。從2018年1月1日起, Seagate 產品必須符合CNS15663第5節「含有標示」要求。本產品符合台灣RoHS。下表符合第5節「含有標示」要求。

產品名稱: 外接式磁碟陣列, 型號: LRDMU06

Product Name: LaCie 2big Dock, Model: LRDMU06

| 單元 Unit | 限用物質及其化學符號 Restricted Substance and its chemical symbol | | | | | |
|--|--|-----------|-----------|----------------------------|---------------|-----------------|
| | 鉛 (Pb) | 汞 (Hg) | 鎘 (Cd) | 六價鉻 (Cr ⁺⁶) | 多溴聯苯 (PBB) | 多溴二苯醚 (PBDE) |
| 硬盤驅動器 HDD | — | ○ | ○ | ○ | ○ | ○ |
| 外接硬盤印刷電路板 Bridge PCBA | — | ○ | ○ | ○ | ○ | ○ |
| 電源 (如果提供) Power Supply (if provided) | — | ○ | ○ | ○ | ○ | ○ |
| 傳輸線材 (如果提供) Interface cable (if provided) | — | ○ | ○ | ○ | ○ | ○ |
| 其他外殼組件 Other enclosure components | ○ | ○ | ○ | ○ | ○ | ○ |

備考 1. “○” 係指該項限用物質之百分比含量未超出百分比含量基準值。

Note 1. “○” indicates that the percentage content of the restricted substance does not exceed the percentage of reference value of presence.

備考 2. “—” 係指該項限用物質為排除項目。

Note 2. “—” indicates that the restricted substance corresponds to the exemption.