

**CFP2107 Series
Intelligent Disk Drive
Product Manual**

October 1995

**Pre-Release
Revision A**

CONNOR[®]

The Storage Answer

3081 Zanker Road

San Jose, CA 95134-2128

(408) 456-4500

FCC Notice

This equipment generates and uses radio frequency energy and, if not installed and used properly; that is, in strict accordance with the manufacturer's instructions, may cause interference to radio and television reception. It has been type tested and found to comply with the limits for a Class B computing device in accordance with the specifications in Part 15 of FCC Rules, which are designed to provide reasonable protection against such interference in a residential installation. However, there is no guarantee that interference will not occur in a particular installation. If this equipment does cause interference to radio or television reception, which can be determined by turning the equipment on and off, you are encouraged to try to correct the interference by one or more of the following measures:

- Reorient the receiving antenna.
- Relocate the computer with respect to the receiver.
- Move the computer into a different outlet so that the computer and receiver are on different branch circuits.

If necessary, you should consult the dealer or an experienced radio/television technician for additional suggestions. You may find the following booklet prepared by the Federal Communications Commission helpful:

How to Identify and Resolve Radio-TV Interference Problems

This booklet (Stock No. 004-000-00345-4) is available from the U.S. Government Printing Office, Washington, DC 20402.

Warning: Changes or modifications made to this equipment which have not been expressly approved by Conner Peripherals, Inc. may cause radio and television interference problems that could void the user's authority to operate the equipment.

Further, this equipment complies with the limits for a Class B digital apparatus in accordance with Canadian Radio Interference Regulations.

Cet appareil numérique de la classe B est conforme au Règlement sur le brouillage radioélectrique, C.R.C., ch. 1374.

Conner and the Conner logo are registered trademarks of Conner Peripherals, Inc. All other trademarks mentioned in this manual are property of their respective owners.

Copyright 1994, 1995, Conner Peripherals, Inc.
All rights reserved.

Document No. 501-071 10/95

Important Information About this Manual

All information contained in or disclosed by this document is considered proprietary by Conner Peripherals, Inc. By accepting this material, the recipient agrees that this material and the information contained therein are held in confidence and in trust and will not be used, reproduced in whole or in part, nor its contents revealed to others, except to meet the purpose for which it was delivered. It is understood that no right is conveyed to reproduce or translate any item herein disclosed without express written permission from Conner Peripherals, Inc.

Conner Peripherals, Inc. provides this manual "as is," without warranty of any kind, either expressed or implied, including, but not limited to, the implied warranties of merchantability and fitness for a particular purpose. Conner Peripherals, Inc. reserves the right to change, without notification, the specifications contained in this manual.

Conner Peripherals, Inc. assumes no responsibility for the accuracy, completeness, sufficiency, or usefulness of this manual, nor for any problem that might arise from the use of the information in this manual.

Table of Contents

1. Overview of the Drives	1
What are the Drives?	1
Differences Between the Models	1
Features of the Drive	2
Drive Composition	3
Mechanical Design Features	3
Drive Assembly Housing	4
Head Positioning Mechanism	5
Read/Write Heads and Disks	5
Data and Power Connections	5
Electrical Design Features	5
Integrated Circuit	5
Circuit Board	5
Firmware	6
2. Specifications	9
Specifications in this Chapter	9
Drive Capacity	10
Formatted Capacity*	10
Physical Configuration	10
Physical Configuration	10
Performance Characteristics	11
Seek Times (typical)*	11
Average Latency	11
Rotation Speed (+0.1%)	11
Controller Overhead	11
Start Time(Power Up)*	11
Stop Time at Power Down	11
Interleave	11
Read/Write Characteristics	12
Recording Method	12
Recording Density (maximum)	12
Flux Density (maximum)	12
Host Interface Characteristics	12
Command Set	12
Data Transfer Rate	12
Maximum Synchronous Transfer Offset:	12
Maximum Tagged Command Queue Depth:	12
Buffer Size:	12
Reliability	13
Data Reliability	13
Component Design Life	13
Mean Time Between Failures:	13
Preventive Maintenance	13
Power Requirements (Typical)	13
Minimum/Maximum Voltage:	13
Environmental Tolerances	14

Magnetic Field:	14
Acoustic Noise:	14
Safety Standards	15
Physical Characteristics - CFP2107E	16
	16
Physical Characteristics - CFP2107S	17
Physical Characteristics - CFP2107W	18
3. Drive Operations	19
Functions of the Drive	19
Drive Operational Modes	19
Data Error Correction	20
Downloadable Microcode	20
Command Execution and Buffer Management	21
Tagged Command Queuing	21
Seek Ordering	21
Rotational Ordering	21
Coalescing	22
Read Look Ahead Code	22
Write Caching	24
4. Installing the Drive	25
Take These Precautions	25
Installing the Drive	25
Installing a CFP2107E	26
Setting the Drive's Jumpers - CFP2107E	26
Setting the SCSI Bus Address - CFP2107E	26
Disabling Spin-Up at Power On - CFP2107E	27
Delaying Spin Up at Power On - CFP2107E	27
Cabling the Drive - CFP2107E	27
Attaching Power to the Drive - CFP2107E	28
Mounting the Drive - CFP2107E	29
Mounting Screw Holes	29
Cooling	29
Installing a CFP2107S	30
Setting the Drive's Jumpers - CFP2107S	30
Setting the SCSI Bus Address - CFP2107S	31
Disabling Spin-Up at Power On - CFP2107S	32
Delaying Spin Up at Power On - CFP2107S	32
Disabling the SCSI Bus Parity - CFP2107S	33
Disabling SCSI Bus Terminator Power (TERMPWR) - CFP2107S	33
Setting the Bus Termination - CFP2107S	34
Cabling the Drive - CFP2107S	35
SCSI Bus Cable	35
Spindle Synchronization	35
Attaching Power to the Drive - CFP2107S	36
Attaching a Remote LED - CFP2107S	36
Mounting the Drive - CFP2107S	36
Mounting Screw Holes	36
Cooling	36
Installing a CFP2107W	38
Setting the Drive's Jumpers - CFP2107W	38

Setting the SCSI Bus Address - CFP2107W	39
Disabling Spin-Up at Power On - CFP2107W	40
Delaying Spin Up at Power On - CFP2107W	40
Disabling the SCSI Bus Parity - CFP2107W	41
Disabling SCSI Bus Terminator Power (TERMPWR) - CFP2107W	41
Using the J5 Auxiliary Connector	41
- SEL0	41
- XTFAULT	42
- SEL1	42
- VUNIQ	42
- SEL2	42
- SPSYNC	43
- SEL3	43
- XTACTV	43
- GROUND	43
+5 Volts	43
- FAULT	43
Setting the Bus Termination - CFP2107W	44
Cabling the Drive - CFP2107W	45
SCSI Bus Cable	45
Mixing Wide and Narrow SCSI Devices on a SCSI Bus	45
Spindle Synchronization	Error! Bookmark not defined.
Attaching Power to the Drive - CFP2107W	47
Attaching a Remote LED - CFP2107W	47
Mounting the Drive - CFP2107W	47
Mounting Screw Holes	47
Cooling	48
5. Interface Physical Characteristics	49
Electrical Description	49
Output Characteristics	49
Input Characteristics	50
Model-Specific SCSI Physical Characteristics	50
CFP2107E (WIDE, 80-pin Single Connector Attachment [SCA])	51
External Terminator Power	51
Internal Termination	51
Cable Requirements	51
Connector Requirements	52
Single Connector Attachment (SCA) Signal Definitions	52
Power	52
Spindle Sync	52
LED Out	52
Motor Start Controls	53
SCSI ID Selection	53
Interface Pin Assignments	54
Interface Timing Requirements	55
Model CFP2107S (Narrow, 50-pin SCSI)	56
External Terminator Power	56
Internal Termination	56
Cable Requirements	57
Connector Requirements	58
Interface Pin Assignments	59
Interface Timing Requirements	60

Model CFP2107W (Wide, Unitized SCSI-3 P-Connector)	61
External Terminator Power	61
Internal Termination	61
J5 Auxiliary Connector Signal Characteristics	62
Cable Requirements	62
Connector Requirements	63
Interface Pin Assignments	64
Interface Timing Requirements	65
6. SCSI Command Implementation	67
SCSI Command Summary	67
Drive Dependent SCSI Data	67
Format Drive Page - 03H	68
Drive Geometry Page - 04H	70
Notch and Partition Parameters Page - 0CH	71

What are the Drives?

The CFP2107 series is a family of high performance 3.5-inch low-profile (1.0 inch high) 2.1GB (formatted) disk drives. They all offer 8.5 millisecond average seek time for Reading, 9.0 millisecond seek time for Writing, with an average latency of only 4.17 ms. High capacity is achieved by utilizing a zone density recording technique using 15 recording zones at an areal density of 317 Mbits per square inch. These drives feature high performance while maintaining low power consumption to reduce power supply current and system cooling requirements in disk arrays.

They are designed to operate on the Small Computer System Interface (SCSI) and are SCSI-2/3 command compatible. The mechanical and major electronic components are identical between the models and differ only in the host interface implementation:

Drive Model	Form Factor	Interface	Capacity
CFP2107E	1 inch high, 3.5 inch	80-pin Single Connector FAST WIDE	2147 MB
CFP2107S	1 inch high, 3.5 inch	50-pin FAST	2147 MB
CFP2107W	1 inch high, 3.5 inch	68-pin FAST WIDE	2147 MB
CFP2107WD	1 inch high, 3.5 inch	68-pin FAST WIDE Differential	2147 MB

The CFP2107WD drive is documented separately in the CFP2107WD SCSI Wide Differential Intelligent Disk Drive Product Manual. The remainder of the drives, which are documented in this manual, are referred to collectively in this manual as “the drive” for simplicity.

Differences Between the Models

The three drive models differ only on the host interface implementation:

CFP2107E: SCSI 80-pin Wide Single Connector Attachment (SCA) interface designed for applications such as Redundant Arrays in which the drives are plugged directly into a backplane. The drive also implements a Wide SCSI interface for high interface bandwidth.

CFP2107S: SCSI 50-pin standard interface designed for applications which implement the standard SCSI-2 architecture.

CFP2107W: SCSI 68-pin Wide interface designed for applications which require high interface bandwidth and the option of cabled interconnect. The drive utilizes the Unitized Connector defined by the Small Form Factor Committee (refer to SFF-8009). The Unitized Connector combines the SCSI-3 P-

connector Wide interface, the standard 4-pin power and a 2mm pin pitch Auxiliary connector into a single molded assembly.

CFP2107WD: SCSI 68-pin wide differential interface designed for applications which require high interface bandwidth and the option of cabled interconnect. The drive utilizes the Unitized Connector defined by the Small Form Factor Committee (refer to SFF-8009). The Unitized Connector combines the SCSI-3 P-connector Wide interface, the standard 4-pin power and a 2mm pin pitch Auxiliary connector into a single molded assembly. The wide SCSI differential implementation conforms to the SCSI-3 Parallel Interface Specification 855D.

Features of the Drive

The drive provides the following features:

- Automatic Spindle Synchronization
- 512 KB segmentable cache buffer with adaptive cache management
- Least Recently Used (LRU) Cache replacement
- Automatic on-the-fly data error correction utilizing a 96-bit Reed-Solomon EDAC.
- Independent 48-bit CRC miscorrection detection.
- On the fly header error detection and correction.
- High performance rotary voice coil actuator with embedded servo system
- No thermal recalibration required to maintain performance levels
- High Shock resistance
- Automatic actuator latch against the inner stop upon power down with dedicated landing zone
- Active Termination with removable Resistor Packs
- Active Negation output drivers for greater interface reliability
- SCSI-2/3 Compatibility
- Dual Microprocessor-controlled diagnostic routines that automatically execute at start-up
- Sealed HDA
- Down-loadable Code through SCSI Interface
- 1,7 run length limited code
- Programmable Block Size (512 or 1024)
- Tagged Command Queuing with Seek Re-ordering and Write/Read Coalescing

Drive Composition

The drive is composed of **mechanical**, **electrical**, and **firmware** elements.

Mechanical Design Features

The drive's hardware includes the components described in the following sections. Figure 1-1 shows the drive top level assembly.

Figure 1-1
Drive Top Level Assembly

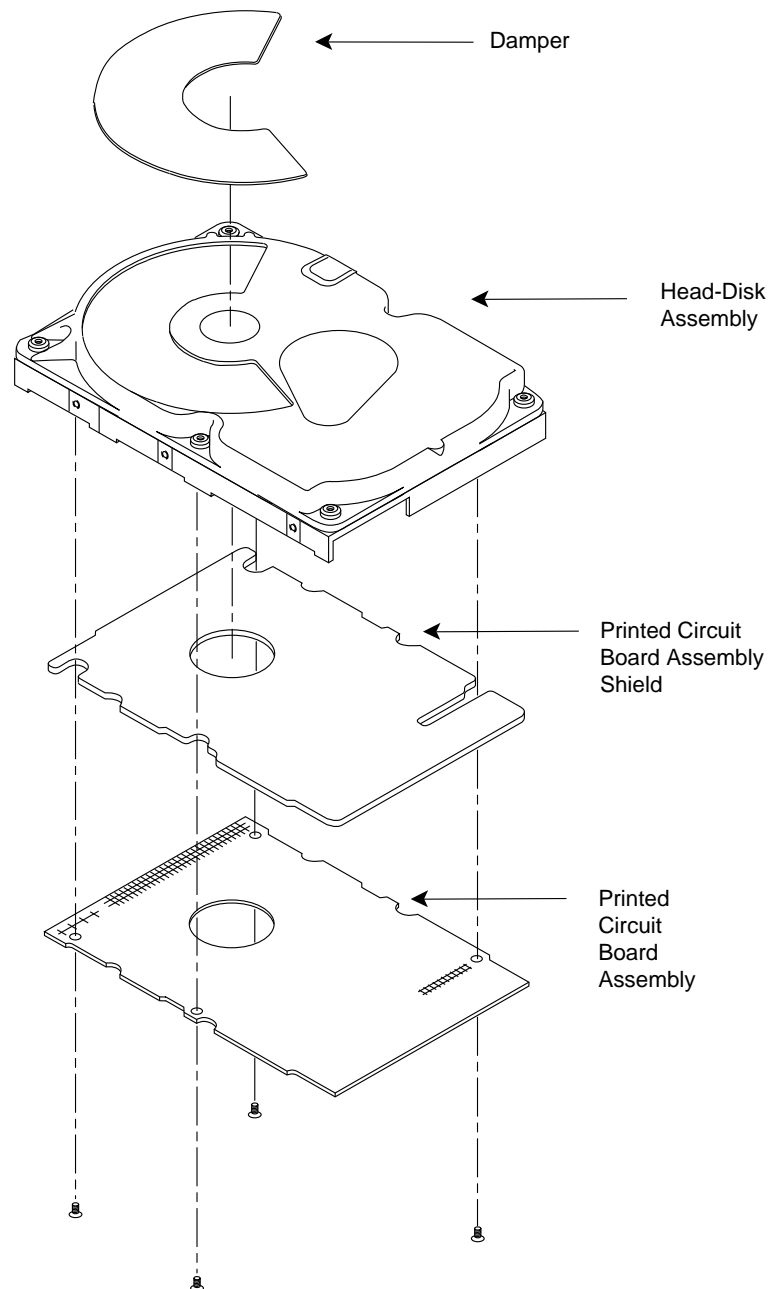

2105-1-1

Drive Assembly Housing

The drive assembly housing, or Head-Disk Assembly (HDA) consists of a die-cast aluminum base on which is mounted a die-cast aluminum cover. Both the base and the cover are fabricated using an alloy and surface finishing process designed to inhibit oxidation. A gasket seals the joint between the base and cover to retard the entry of moisture and environmental contaminants from the assembly.

This assembly, the head-disk assembly, contains an integral 0.3 micron filter, which maintains a clean environment. Critical drive components are contained within this contaminant-free environment. Figure 1-2 shows the HDA and the major assemblies contained within it:

Figure 1-2
Head-Disk Assembly

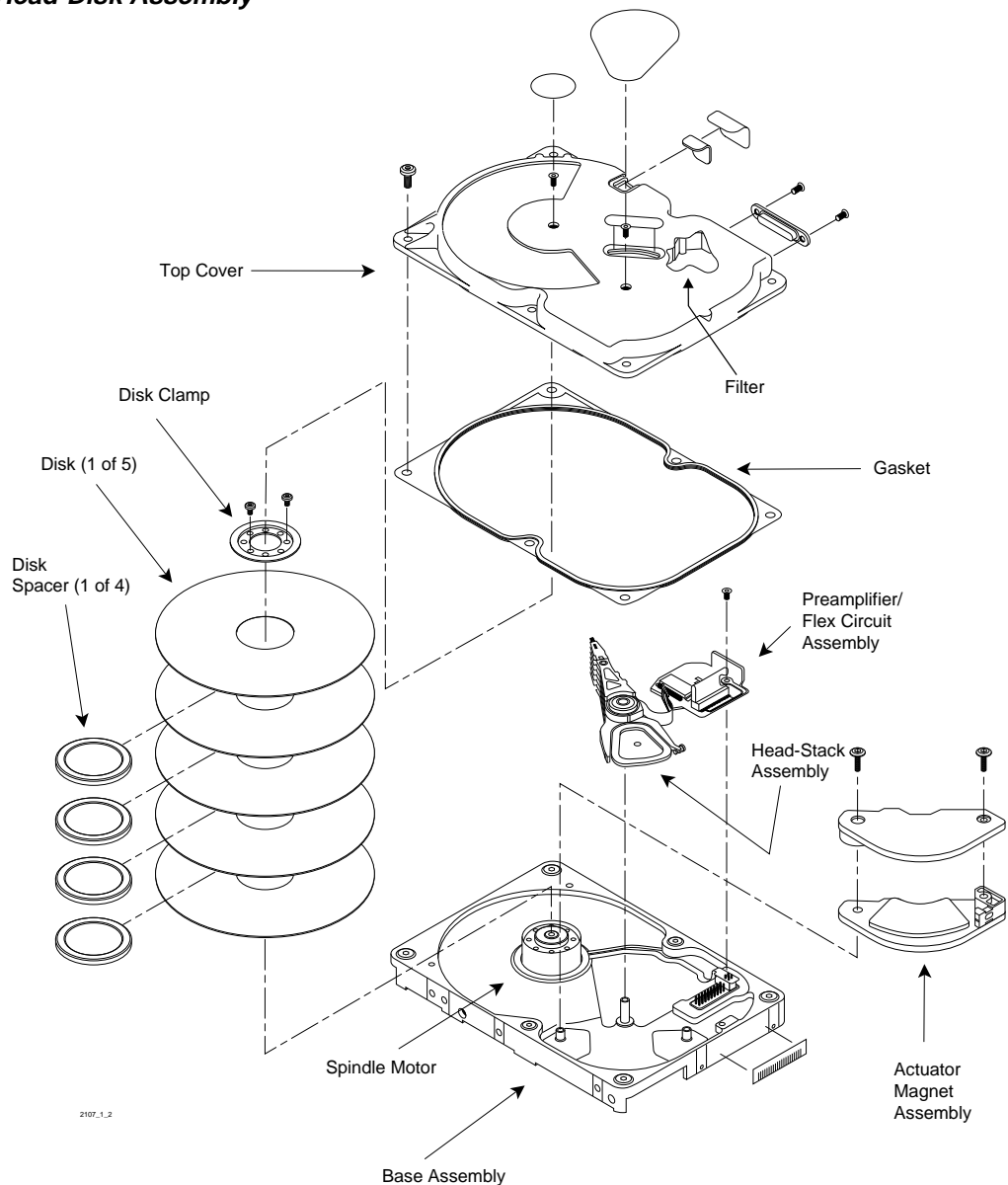

Drive Motor and Spindle

A brushless DC direct-drive motor assembly is mounted on the drive's base. The motor rotates the drive's spindle at 7200 RPM. The motor/spindle assembly is dynamically balanced to provide minimal mechanical runout to the disks. A dynamic brake is used to provide a fast stop to the spindle motor and return the heads to the landing zone when power is removed.

Head Positioning Mechanism

The read/write heads are supported by a mechanism coupled to a rotary voice coil actuator.

Read/Write Heads and Disks

Data is recorded on 95mm diameter disks through 3370-type 50% nano-slider thin film heads with transverse pressure contour (TPC) air bearing surfaces. The TPC air bearing surface allows the head to fly at a uniform height regardless of radial position. This improves data reliability and allows the aerial density to be more uniform with radius. The CFP2107 series contains five sputtered thin film disks with ten data surfaces and ten read/write heads.

At power-down, the heads are automatically retracted to the inner diameter of the disk and are latched and parked on a landing zone that is inside the data tracks.

Data and Power Connections

Data and power connections to the drive are different between the drive models. Refer to chapter 4 for information regarding a specific model's requirements.

Electrical Design Features

Integrated Circuit

A single integrated circuit (IC) is mounted within the sealed hard drive assembly in close proximity to the read/write heads. The IC provides head selection, read pre-amplification, and write drive circuitry.

Circuit Board

The drive's dual-microprocessor-controlled circuit board provides the remaining electronic functions, which include:

- read/write circuitry
- rotary actuator control
- interface control
- spin speed control
- auto-park
- power management

The background processor is a 16-bit Motorola 68HC16. The entire data path between the serializer-deserializer and the interface chip, including the buffer

(cache) is 16 bits wide to provide high data throughput. The SCSI interface chip manages a 16-bit to 8-bit conversion prior to transacting data over the SCSI bus for 8-bit narrow SCSI applications.

The data buffer (cache) utilizes a 256K x 16 Dynamic RAM. Data path integrity is ensured by using a 4-byte CRC which is appended to the data upon receipt by the SCSI Interface Chip. This CRC is verified by the buffer manager when the data is taken out of the buffer to be written to the disk and the CRC is written with the data. A typical sector data field consists of 512 bytes of data, 4 bytes of CRC and 11 bytes of Error Detection And Correction (EDAC) code. The same CRC checks are performed during an outbound process and the CRC is stripped from the data prior to sending it to the Host.

The SCSI interface functions are managed by a 8-bit Motorola 68HC11 microprocessor. Low SCSI transaction overhead is maintained by automating common SCSI bus phase sequencing using a state machine in the SCSI Interface Chip chip.

Read/Write Channel

The Read/Write channel, in addition to the preamplifier discussed earlier, consists of a single ntegrated circuit which contains:

- Pulse Detector
- Data Separator
- Time base

Firmware

The drive's firmware can be considered in two parts. The first part principally resides in the ROM for the 68HC16 background processor. This processor is responsible for:

- starting the spindle motor and maintaining precise rotational speed
- controlling track following and actuator motion during seeking
- managing background R/W activity
- power management
- monitoring the overall health of the drive.

The interface processor's control microcode resides in both ROM and RAM. The RAM portion of the microcode can be upgraded in the field with using software. Additional information regarding the RAM code can be found in Chapter 3, page 20. The interface processor firmware functions include:

- reporting drive status and error conditions to the host
- manage operating parameters for the drive
- parsing the Command Descriptor Block and checking for illegal fields
- converting the LBA to CHS and initiating read and write operations to the background processor
- defect management
- serial port communications

Since parsing/decoding of commands and execution of the Read/Write functions are handled by separate processors, command execution can be overlapped in multiple initiator or Tagged Command Queuing environments. Functions such as seek re-ordering and command coalescing can also be overlapped when the drive is operating with a host environment capable of supporting Tagged Command Queuing.

For more information on the drive's interface implementation and command set, refer to the Eleventh Generation SCSI Interface Manual.

Specifications in this Chapter

This chapter provides the following specifications for the drive:

- drive capacity
- physical configuration
- performance characteristics
- read/write characteristics
- reliability
- power requirements
- environmental tolerances
- safety standards
- physical characteristics

Drive Capacity

Formatted Capacity*

- CFP2107 Series: 2147 MB

*1MB is equal to 10⁶ or 1,000,000 bytes

Physical Configuration

Specification:	CFP2107 Series
Disk Type	Sputtered Thin film
Head Type	Thin Film - TPC
Actuator Type	Rotary Voice-Coil
Number of Disks	5
Data Surfaces	10
Data Heads	10
Servo	Embedded
Tracks per Surface	3999
Track Density @ 0° Skew	4090 TPI
Bytes per Block	512, 1024
Blocks per Drive (logical @ 512)	4,194,304

Physical Configuration

	<i>Data Rate (Mbits/sec)</i>	<i>Data Tracks per Zone per Surface</i>	<i>User Sectors per Track *</i>
Zone 0 (OD)	87.2	1014	124
Zone 1	85.6	268	122
Zone 2	81.3	331	119
Zone 3	78.9	188	113
Zone 4	77.0	157	111
Zone 5	75.4	128	108
Zone 6	72.6	217	105
Zone 7	68.2	340	99
Zone 8	65.6	185	95
Zone 9	63.9	118	92
Zone 10	61.7	156	89
Zone 11	60.4	87	87
Zone 12	57.7	187	83
Zone 13	51.5	432	79
Zone 14 (ID)	47.7	191	69

* The physical track configuration contains one spare sector per track.

Performance Characteristics

Seek Times (typical)*

- Track to Track: 2.0 msec
- Average (read/write): 8.5/9.0 msec **
- Full Track: 18 msec

* The timing is measured from the time the last byte of the command descriptor block is written to the time seek is initiated by the drive operating at nominal DC input voltage and nominal operating temperature.

** The average seek time is determined by averaging the seek time for a minimum of 1000 seeks of random length over the surface of the disk.

Average Latency

- 4.17 milliseconds

Rotation Speed (+0.1%)

- 7200 RPM

Controller Overhead

- 700 μ sec

Start Time(Power Up)*

- 0 RPM to Ready
 - Typical: 15 seconds
 - Maximum: 40 seconds

* These numbers assume spin recovery is not invoked. If spin recovery is invoked, the maximum could be 40 seconds. Briefly removing power can lead to spin recovery being invoked.

Stop Time at Power Down

- Typical: 10 seconds
- Maximum: 15 seconds

Interleave

- 1:1

Read/Write Characteristics

Recording Method

- 1,7 RLL code

Recording Density (maximum)

- 77,500 bits per inch

Flux Density (maximum)

- 58,100 bits per inch

Host Interface Characteristics

Command Set

- SCSI-2 (refer to the Eleventh Generation SCSI Technical Reference Manual for command implementation)

Data Transfer Rate

- To/from Buffer, synchronous narrow: 10.0 MByte/second
- To/from Buffer, synchronous wide: 20.0 MByte/second

Maximum Synchronous Transfer Offset:

- 15 bytes/words

Maximum Tagged Command Queue Depth:

- 32 commands

Buffer Size:

- 512 KB, segmentable

Reliability

Data Reliability

- < 1 non-recoverable error in 10^{14} bits read

Component Design Life

- 5 years

Start/Stop Cycles

- 20,000 minimum

Mean Time Between Failures:

- 1,000,000 power-on hours*

* Projected MTBF based on comparison of similar Conner products

Preventive Maintenance

- None

Power Requirements (Typical)

<i>Mode</i>	<i>+12V DC (typical)¹</i>	<i>+5V DC (typical)</i>	<i>Power (typical)</i>	<i>Power (maximum)</i>
Read/Write	575 mA	645 mA	10.1 W	10.5 W
Seek (40%)	630 mA	415 mA	9.6 W	10.3 W
Random (100%) Seek	1040 mA	420 mA	14.6 W	15.6 W
Idle	550 mA	425 mA	8.7 W	9.1 W
Standby	1 mA	585 mA	2.9 W	3.2 W
Spin-up	2.0 A	720 mA	n/a	2.3 A @12V

¹ Typical conditions are both voltages at nominal value, room temperature (25° C) ambient to the drive without terminators installed. Maximum power is when the supply voltage is at the worst case condition.

Minimum/Maximum Voltage:

- +5V: $\pm 5\%$
- +12V: $\pm 5\%$

Maximum Peak-to-Peak Allowable Noise (DC to 1 Mhz: equivalent resistive load):

- +5V: 2%
- +12V: 1%

Environmental Tolerances

Temperature:

- Operating: 5° to 55° C
- Non-operating: -40° to 60° C
- Thermal Gradient: 20° C per hour maximum

Relative Humidity (non-condensing):

- Operating: 5 to 95%
- Non-operating: 5 to 95%
- Maximum Wet Bulb: 29°C

Altitude (relative to sea level):

- Operating: -200 to 10,000 feet
- Non-operating: 40,000 feet (maximum)
- Altitude Gradient: 1,000 feet/minute

Shock (half-sine pulse, 11 ms duration):

- Operating: 5G peak without non-recoverable errors
- Non-operating: 75G without non-recoverable errors

Vibration (swept-sine, one octave per minute):

- Operating
 - 5 - 32 Hz: 0.010 inch displacement; peak to peak
 - 33 - 400 Hz: 0.5G without non-recoverable errors
- Non-operating
 - 5 - 28 Hz: 0.100 inch displacement; double amplitude
 - 29 - 400 Hz: 4G peak

Magnetic Field:

- The disk drive will meet its specified performance while operating in the presence of an externally-produced magnetic field under the following conditions:

<i>Field Frequency</i>	<i>Intensity</i>
DC	6 gauss
to 700 KHz	7 milligauss
700 KHz to 1.5 Mhz	3 milligauss

Acoustic Noise:

- The acoustic level will not exceed 4.5 Bels sound power in Idle Mode .

Safety Standards

The drive is designed to comply with relevant product safety standards, including:

- UL 478, 5th edition, Standard for Safety of Information Processing and Business Equipment
- UL 1950, Standard for Safety of Information Technology Equipment
- CSA 22.2 #220, Information Processing and Business Equipment
- CSA 22.2 #950, Safety of Information Technology Equipment
- IEC 380, Safety of Electrically Energized Office Machines
- IEC 950, Safety of information Technology Equipment Including Electrical Business Equipment
- VDE 0805, VDE 0805 TIEL 100, and VDE 0806
- Complies with FCC Class B, Part 15, Subpart J

Physical Characteristics - CFP2107E

Height:

- 1.0 inch \pm .020

Width:

- 4.0 inches \pm .020

Depth:

- 5.75 inches \pm .030

Weight:

- 1.4 pounds

Figure 2-2
The Drive's Physical Dimensions

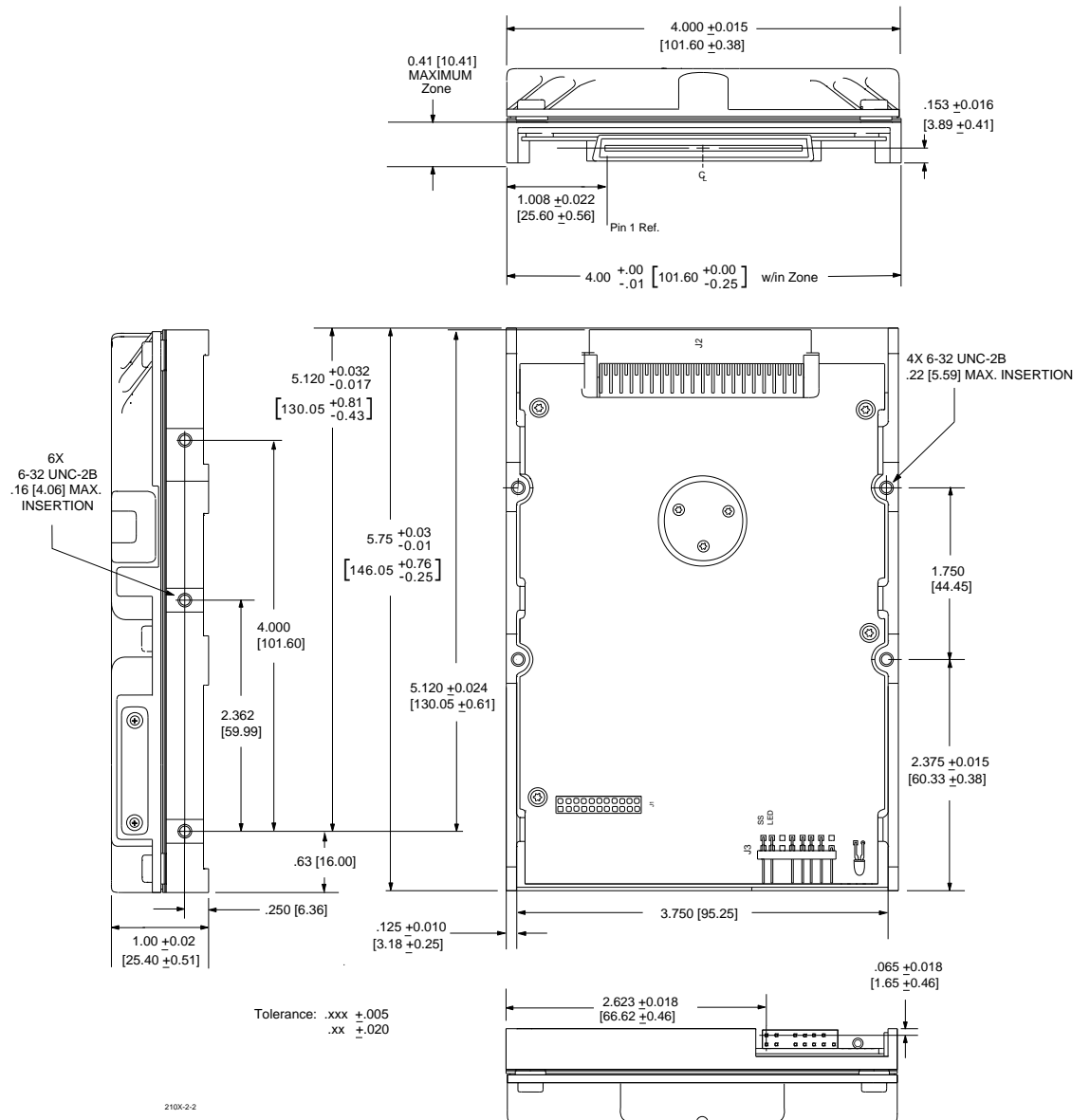

Physical Characteristics - CFP2107S

Height:

- 1.0 inch \pm .020

Width:

- 4.0 inches \pm .020

Depth:

- 5.75 inches \pm .030

Weight:

- 1.4 pounds

Figure 2-3
The Drive's Physical Dimensions

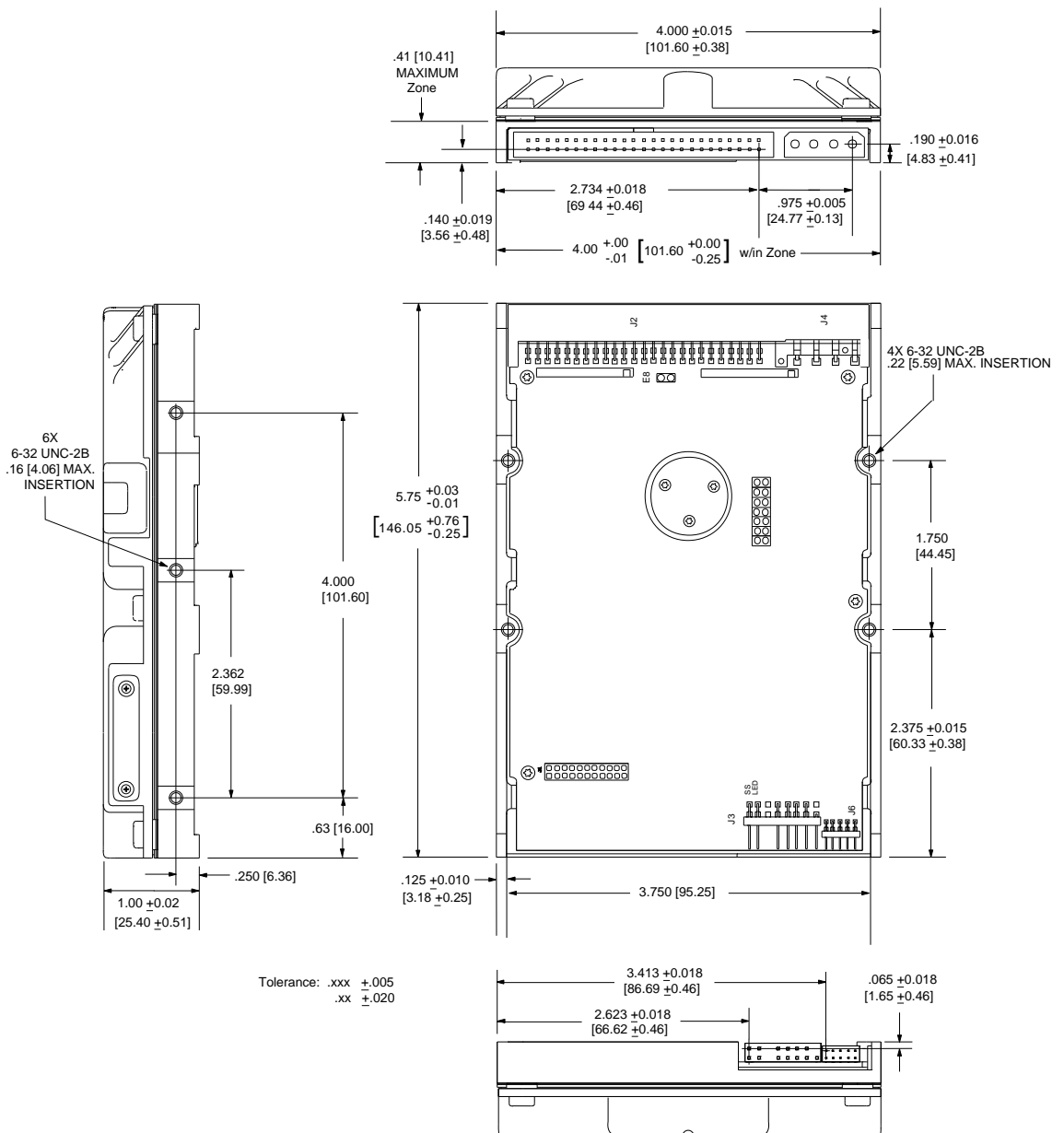

Physical Characteristics - CFP2107W

Height:

- 1.0 inch \pm .020

Width:

- 4.0 inches \pm .020

Depth:

- 5.75 inches \pm .020

Weight:

- 1.4 pounds

Figure 2-4
The Drive's Physical Dimensions

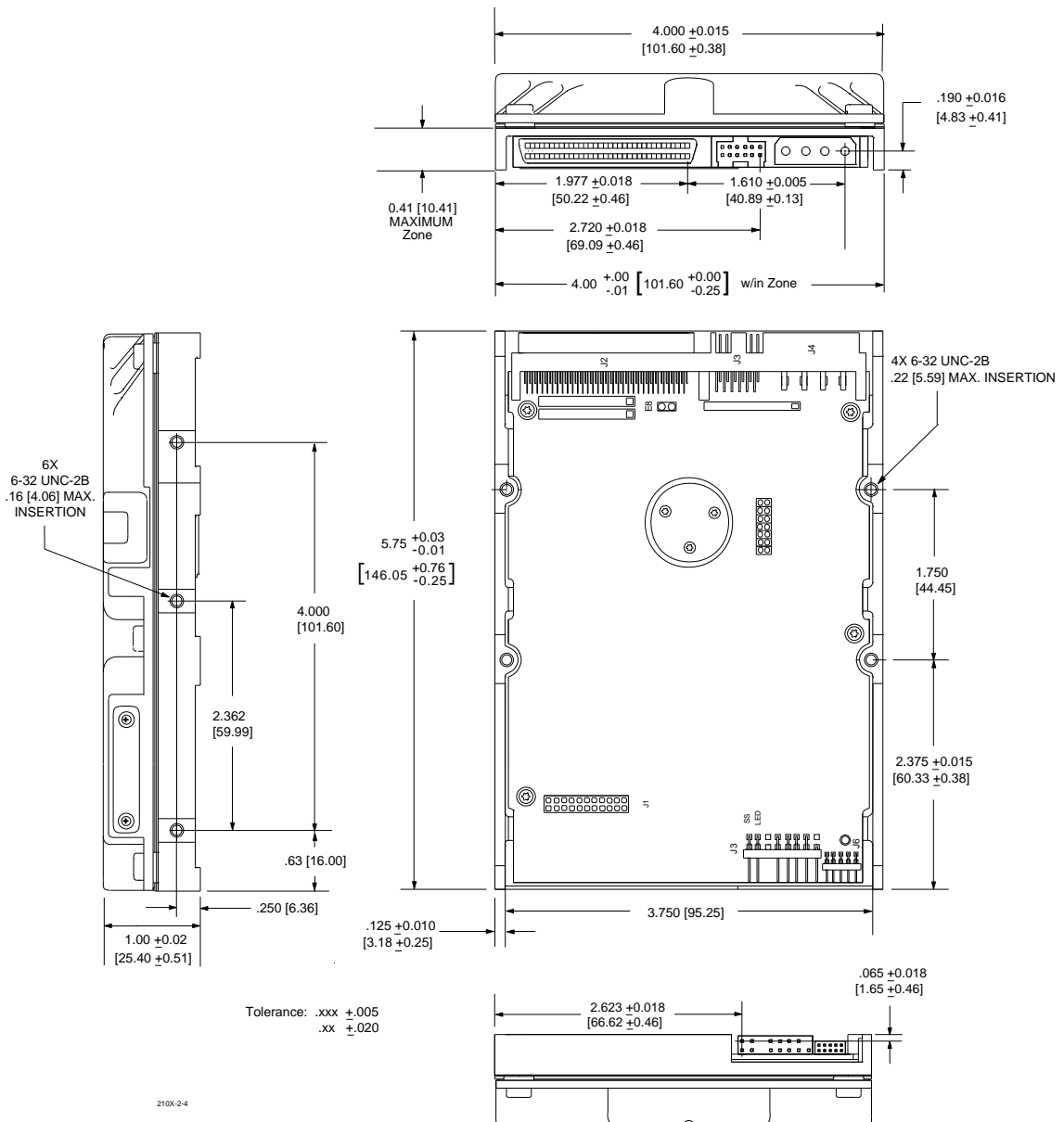

Functions of the Drive

This chapter describes certain operational aspects of the drive, including discussions of:

- drive operational modes
- error correction
- read error recovery
- downloadable microcode
- buffer management

Drive Operational Modes

For the purpose of defining power requirements the following modes have been defined:

- **Read/Write Mode** occurs when the drive is operating without seeking or head switching while data is read from or written to the disk continuously.
- **Seek Mode (40%)** occurs when 1/3 stroke seeks are performed at a 40% seek duty cycle. While the actuator is not in motion the drive is internally reading sector information and data.
- **Random (100%) Seek** occurs when the drive continuously seeking to random track locations without transferring any data. This condition does not occur in an applications environment. Adequate cooling must be provided when testing in this mode to ensure environmental limits are not exceeded.
- **Idle Mode** occurs when the drive is not reading, writing, or seeking. The motor is up to speed and the **Drive Ready** condition exists. The actuator is residing on the last-accessed track.
- **Standby Mode** occurs when the motor is stopped and the actuator is latched in the landing zone. The drive will enter Standby mode after power-on reset if the Disable Spin jumper is installed or the DSPN bit in MODE SELECT page 0 is set. A STOP UNIT command will also place a drive into Standby Mode. The drive will spin up and go into Idle mode when a START UNIT command is issued or on a timed basis by SCSI ID if the SDLY bit is set in MODE SELECT page 0. Refer to the MODE SELECT and MODE SENSE commands in the Eleventh Generation SCSI Interface Manual for additional details.
- **Spin-Up Mode** occurs while the drive's spindle motor is being spun up to speed after initial power on or after exiting Standby Mode.

Data Error Correction

The drive uses a three way interleaved 96-bit Reed-Solomon code to perform error correction. An additional 48-bit Cyclic Redundancy Code (CRC) provides additional miscorrection detection. For each 512-byte block, the on-the-fly error correction polynomial is capable of correcting:

- one error burst of up to 41 bits in length
- two error bursts each up to 17 bits in length

The miscorrection probability is less than 1 bit in 10^{24} bits transferred.

Downloadable Microcode

The SCSI interface code is split into two parts which are designated as ROM or RAM code. The ROM code contains the basic SCSI operating code and code to support commands such as INQUIRY, TEST UNIT READY, REQUEST SENSE, START/STOP UNIT, etc., which may have to be responded to prior to the drive being in a ready state. The part of the interface code referred to as RAM code resides on an area of the disk which is reserved to the drive and is not directly accessible through the interface. This code is referred to as RAM code because it is read from the disk and is loaded into static RAM after power is applied to the disk, as soon as the drive is able to read from the disk.

The RAM code may be upgraded on the disk via the factory serial port or through the interface using the WRITE BUFFER command. Refer to the WRITE BUFFER command in the Eleventh Generation SCSI Interface Manual for a discussion of the procedure.

Command Execution and Buffer Management

The drive dynamically adapts to queuing and non queuing depending on whether a Queue Tag Message is presented with the command. A 512Kbyte onboard segmented buffer is dynamically configured to adapt to the particular drive configuration or operating environment. Look ahead reads are performed by the drive when there are no queued commands awaiting execution. Look ahead reads are not performed when there are commands in the queue since another command will be waiting for execution as soon as the current command completes and because the queue affords pre-knowledge of subsequent commands instead of having to anticipate them.

Tagged Command Queuing

The drive when operating in a Tagged Command Queuing environment can queue up to 32 commands. Commands in the queue are re-ordered to maximize I/O throughput. There are three types of re-ordering that the drive may do:

- Seek Ordering based on physical cylinder position in order to minimize actuator motion
- Rotational Position Ordering (RPO) to minimize rotational delays
- Read/Write Coalescing to minimize overhead

Command re-ordering is controlled by Message Code (Simple, Head of Queue or Ordered Queue) during the Message Phase. Re-ordering of seeks issued with a Simple Queue Tag message may also be restricted using the Queue Algorithm Modifier bits in MODE SELECT page 0A_H. Refer to the Eleventh Generation SCSI Interface Manual for additional information on Messages and MODE SELECT page 0A_H.

Seek Ordering

Commands in the queue which involve seeks are re-ordered to minimize actuator motion using a C-SCAN (circular scan) method. Seeks already in the queue are re-ordered so they can be executed sequentially on a sweep toward the inner diameter (ID). Any new seeks entering the queue ahead of the sweep is ordered for execution during the current sweep. Any new commands requiring seeks entering the queue behind the current sweep are held for re-ordering during the next OD to ID sweep. When there are no more commands in the queue ahead of the current sweep, the drive executes the command with a target address closest to the OD.

Rotational Ordering

RPO is done whenever there is more than one command in the queue waiting for execution. The RPO algorithm accounts for both actuator seek time and rotational latency time to determine which command in the queue will require the least amount of time (from completion of the currently executing command) to reach the target location.

Coalescing

Read and Write commands are coalesced (combined into a single operation to the background processor) to minimize inter processor communication overhead and reduce mechanical motion. On a read operation, the data associated with each queue tag is transmitted to the host as the buffer is filled by the background processor. On write operations, the drive will connect to the initiator(s), receive the data into its buffer and disconnect; coalescing sequential data in the buffer before initiating the write to the background processor. The drive will reconnect with each of the writes, using the queue tags, completing the command after the data has been written to the disk. This operation provides the performance of write caching without the exposure of completing the command prior to writing the data to the disk.

Read Look Ahead Code

The Read Look Ahead function of the code executes commands sequentially as they are received from the initiator(s). Commands from multiple initiators may be queued and overlapped so that the subsequent command can be parsed while the current command is being executed.

Buffer operations default to Read Look Ahead enabled and Write Caching disabled. MODE SELECT page 8, byte 2, bit 0 (RCD), when set to one disables the read look-ahead cache function and bit 2 (WCE), when set to one enables write cache. In addition, MODE SELECT page 8, byte 3 contains two fields which control the retention priority for reads and writes. Refer to the Eleventh Generation Disk Drive SCSI Interface Manual for additional details.

When a read command is received by the disk drive, the cache tables are searched to determine if the requested data is contained in any of the cache segments (a cache hit). If there is no cache hit, the Least Recently Used (LRU) segment is selected and a read from disk is initiated into that segment which is now considered the Active Segment. The retention of data already transferred to the host and read look ahead in the Active Segment buffer is controlled by the state of the Read Retention Priority.

Read Retention On (Read Retention Priority = 0 or F):

The interface processor initiates a full segment read of 253 sectors (FD_H blocks) to the background processor. There are three different situations which would be considered a cache hit on a subsequent read.

- **Full:** All of the data requested is transferred from the buffer segment and retained.
- **Partial:** Some but not all of the data is cached in a buffer segment. If the cached data is in the Active Segment and the remaining data is part of the full segment read, the drive will transfer the requested data from the buffer as the background process fills it. If the cached data is in the Active Segment but the remaining data is not part of the full segment read, the drive will turn off read retention until the next Active Segment miss occurs and issues a new read (forever) to the background process. This allows the drive to adapt to long sequential reads even in read retention mode. If the data is part of an Inactive Segment, a new full segment read is initiated, making this the Active Segment.
- **Potential:** If none of the data is in the Active Segment, but is part of the full segment read, the drive will transfer the data as it becomes available.

Read Retention Off (Read Retention Priority = 1): The interface processor initiates a "read forever" command to the background processor and the buffer segment is treated as a circular buffer which is back filled as sectors are transferred to the host. There are three different situations which would be considered a cache hit on a subsequent read.

- **Full:** All of the requested data is cached in a buffer segment. If it is the Active Segment, the data will be transferred to the host and refilled with next sequential data. If the data is in an Inactive Segment, the data is transferred to the host and retained.
- **Partial:** This is when some, but not all of the data is cached in a buffer segment. If the data is in the Active Segment, data is transferred to the host as the background process fills the buffer and the "read forever" is allowed to refill the buffer. If the data is in an Inactive Segment, the cached data is transferred and a new read operation is initiated for the remaining data, making this the Active Segment.
- **Potential:** None of the data is cached. The active segment is checked and if the requested data is within 63 sectors of being read, the drive will allow the "read forever" operation to continue and the data is transferred to the host when it is available.

Write Caching

Write Caching allows multiple write commands operating on sequential blocks to be written to the medium without losing a motor revolution between commands. Write caching is enabled by setting the WCE bit in MODE SELECT page 8 to one.

The drive will send good status and command complete following the data out phase of a cached write command. The drive will cache writes when the following conditions are met:

- Two or more write commands (Op Code 0A_H or 2A_H) execute consecutively without an intervening command.
- The write commands address consecutive logical block ranges.
- At least one logical block of data has been received in the buffer from the second write command in time to allow the medium to be written before an additional spindle revolution would be required.
- Both writes are from the same initiator.
- Neither write is a linked command.

If the drive encounters an error during a cached write operation, the drive will respond by:

If AWRE (MODE SELECT page 01_H) is 0: the drive will report a CHECK CONDITION on the next command and the response from a REQUEST SENSE will be a deferred error. (Asynchronous event notification is not supported by this drive.) Refer to the Eleventh Generation SCSI Interface Manual for additional details.

If AWRE (MODE SELECT page 01_H) is set to 1: the drive will attempt to dynamically reassign the block of data and complete the operation. If the reassignment fails, the drive will continue to reassign the block until all the space in the grown defect list is filled (147 sectors, maximum).

Take These Precautions

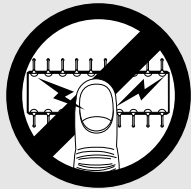

To protect your equipment from electrostatic damage, perform the installation at a static-safe workstation. If one is not available, follow these guidelines:

1. Work in an uncarpeted area.
2. Before removing the equipment from its anti-static bag, discharge static electricity by touching your computer's metal chassis (or any other grounded object) while touching the anti-static bag.
3. Do not touch circuit boards unless instructed to do so.

0170

Installing the Drive

To install the drive, you must:

- set the drive's jumpers, if desired
- attach a data cable to the drive
- attach power to the drive
- mount the drive

These procedures differ between the various drive models.

Installing a CFP2107E

The following paragraphs describe the installation procedure for a 16-bit Single Connector Attachment (SCA) interface, model CFP2107E drive.

Setting the Drive's Jumpers - CFP2107E

There are no jumpers to set on the model CFP2107E drive since all the necessary control signals are on the SCA connector. This drive is intended for applications where the drive is configured at the interface when the drive is plugged into the interface connector.

Setting the SCSI Bus Address - CFP2107E

The SCSI bus ID of the drive is set by grounding the Interface bus signals shown below in Table 4-4.

Table 4-4
Setting the SCSI ID

SCSI ID	SCSI ID(0)	SCSI ID(1)	SCSI ID(2)	SCSI ID(3)
0	Open	Open	Open	Open
1	Ground	Open	Open	Open
2	Open	Ground	Open	Open
3	Ground	Ground	Open	Open
4	Open	Open	Ground	Open
5	Ground	Open	Ground	Open
6	Open	Ground	Ground	Open
7	Ground	Ground	Ground	Open
8	Open	Open	Open	Ground
9	Ground	Open	Open	Ground
10	Open	Ground	Open	Ground
11	Ground	Ground	Open	Ground
12	Open	Open	Ground	Ground
13	Ground	Open	Ground	Ground
14	Open	Ground	Ground	Ground
15	Ground	Ground	Ground	Ground

Disabling Spin-Up at Power On - CFP2107E

Spin up upon application of power to the drive can be disabled by grounding the RMT_START line on the interface. Disabling spin up on application of power can also be enabled by setting the DSPN bit in MODE SELECT page 00_H (Vendor Specific Parameters). The Host must issue a START UNIT command to cause the drive to spin up. Refer to the Eleventh Generation SCSI Technical Reference Manual for additional information regarding the MODE SELECT and START/STOP UNIT commands.

Table 4-5
Disabling Spin Up at Power On

<i>RMT_START</i>	<i>DSPN</i>	<i>Result</i>
Ground	0	Spin Disabled
Ground	1	Spin Disabled
Open	0	Spin up on Power On
Open	1	Spin Disabled

Delaying Spin Up at Power On - CFP2107E

Grounding the DLYD_START signal on the interface delays spin up on power-up by the value of the drive's SCSI ID multiplied by 4 seconds (i.e. SCSI ID 4 will delay 16 seconds). Delaying spin up on application of power can also be enabled by setting the SDLY bit in MODE SELECT page 00_H (Vendor Specific Parameters). Refer to the Eleventh Generation SCSI Technical Reference Manual for additional information regarding the MODE SELECT command.

Table 4-6
Delaying Spin Up at Power On

<i>DLYD_START</i>	<i>SDLY</i>	<i>Result</i>
Ground	0	Spin Delayed
Ground	1	Spin Delayed
Open	0	Spin up on Power On
Open	1	Spin Delayed

Cabling the Drive - CFP2107E

The drive may be connected to the host SCSI interface directly through a backplane SCA connector or through cabling. Both the connector and cabling is described in Chapter 5.

The design of the SCSI bus interconnect system should meet the following guidelines, particularly with FAST SCSI-2 systems:

- Do not route the data signals next to any high frequency or large current switching signals. Unreliable drive operation can result from improper signal routing.
- Signal line stubs should not exceed 0.1 meter (4 inches).
- There should be 0.3 meters (12 inches) of transmission line between drives.
- The total length of any signal line should not exceed 6 meters (20 feet) and may have to be reduced if excessive impedance discontinuities exist on the bus.
- Maintain a minimum of 0.050 inches (1.27mm) gap between adjacent signal runs to control crosstalk between signal lines.
- Signals routed over a ground plane or between ground planes have different characteristic impedance. Signals with critical timing like REQ, ACK and Data should be routed similarly.

The signal length between devices should either be spaced shorter than the stub length, which treats a group of devices as a lumped element, or far enough apart that a transmission line exists (0.3 meters or 12 inches). These signal length considerations should include the length of signal traces and connectors on the printed circuit board. The diagram below shows how it is possible to interconnect six 1-inch height drives over a relatively short length of interconnect.

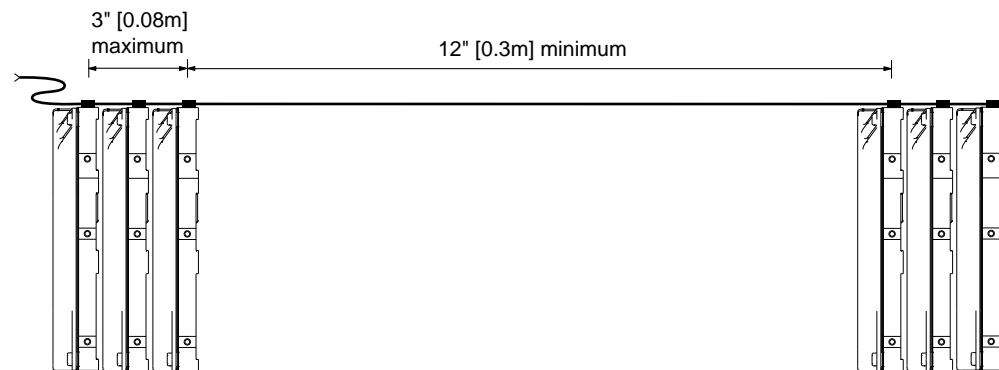

These guidelines apply to both cabled and backplane implementations. Guidelines specifically for cabled implementations can be found on page 35. While it is possible to connect SCA drives using a cable, users should be aware that the mating connector is designed for 0.025 inch (0.63 mm) pitch 30 AWG wire. There are four +12 volt and three +5 volt line pairs carrying power to the drive on the SCA so spin up must be staggered to connect two drives on the same cable and the cable length kept to a minimum. Otherwise, there should only be one drive per cable.

Attaching Power to the Drive - CFP2107E

The drive is powered through the SCA connector.

Mounting the Drive - CFP2107E

The drive is designed to be used in applications where the unit may experience shock and vibrations at greater levels than larger and heavier disk drives will tolerate.

The design features which allow greater shock tolerance are the use of rugged heads and media, a dedicated landing zone, closed loop servo positioning and specially designed motor and actuator assemblies.

Mounting Screw Holes

Six side, or four bottom base mounting points are provided to the customer. The drive is mounted using 6-32 UNC -2B X 0.16 maximum insertion length screws. Refer to Figure 2-2 in Chapter 2 for the location of the mounting holes. The drive may be mounted in any orientation.

Cooling

The enclosure design for the drive must provide adequate provision for removing heat generated by the drive via conduction or air flow convection cooling. The maximum operating temperature for the drive is 55°C. A temperature sensor mounted on the drive at the location shown below should remain at or below 55°C while the drive(s) are operated at the worst case condition.

The enclosure design should allow air flow above and below the drive to cool both the HDA and printed circuit board assembly. The drive(s) should be positioned in the path of least resistance to the flow of air so that the flow is not routed around the drive. Placing the drive at the source of the shortest air flow path helps to ensure adequate air flow and avoids pre-heating of the air by other heat generating sources.

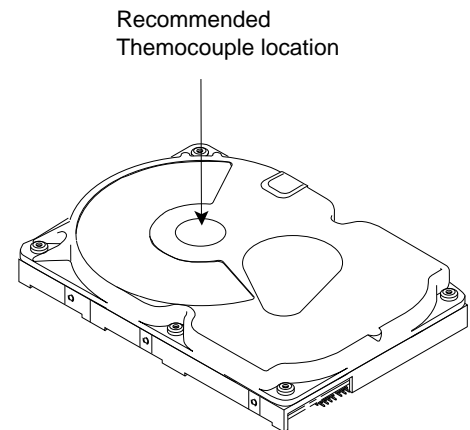

Installing a CFP2107S

The following paragraphs describe the installation procedure for a 8-bit, 50-pin SCSI-2 interface, model CFP2107S drive.

Setting the Drive's Jumpers - CFP2107S

Figure 4-3 shows you where the drive's jumpers are located.

Figure 4-3
Jumper Locations

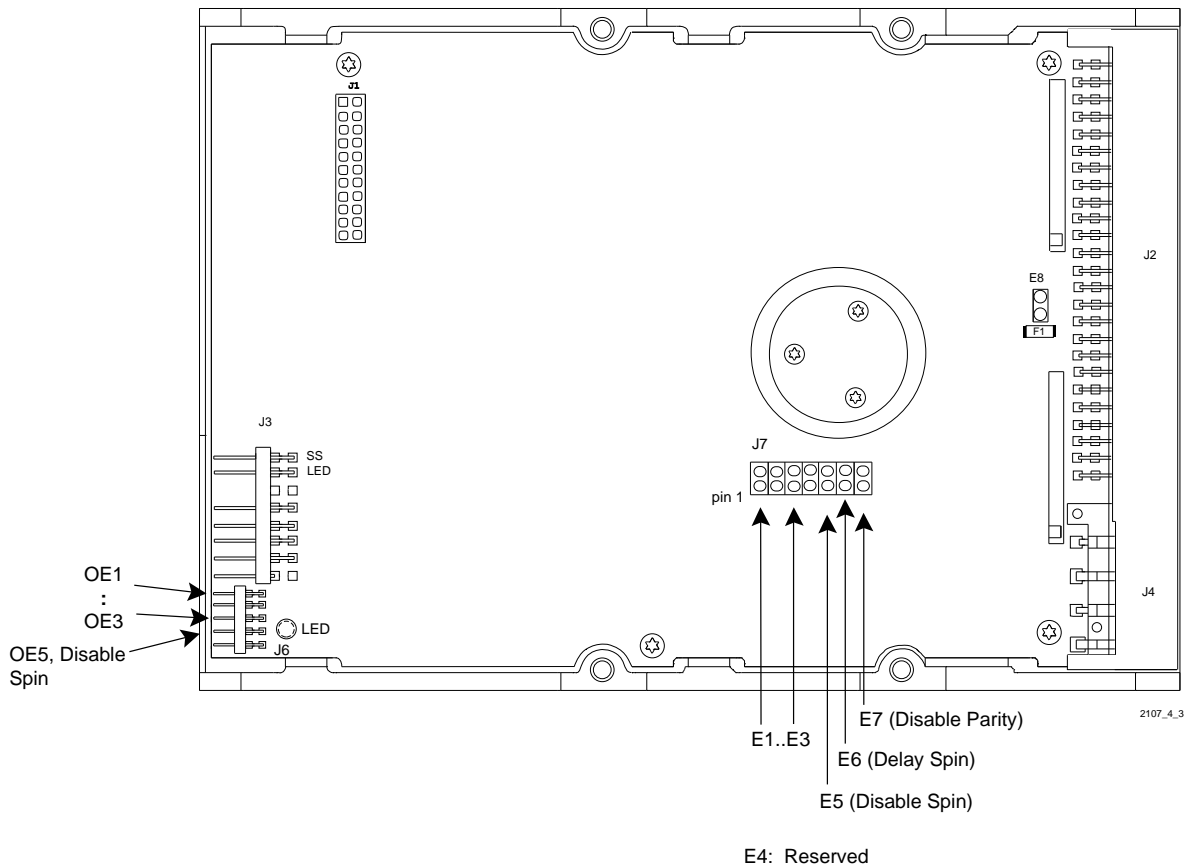

Setting the SCSI Bus Address - CFP2107S

There are three jumpers available for configuration of the SCSI ID: E1, E2, and E3.

An optional 2mm pin pitch right angle header is located on the front of the PCBA (opposite the SCSI interface connector) which allows changing the SCSI IDs while the drive is mounted in the system. The header includes three pins, 0E1, 0E2 and 0E3 which can alternatively be used to select the SCSI Bus address. This connector may also be used to cable the SCSI ID select to a remote switch. A receptacle connector Amp P/N 111622-1 or equivalent can be used to connect a ribbon cable to this header.

Table 4-6 defines the relationship between the jumpers and the SCSI ID:

Table 4-7
Setting the SCSI ID

<i>Optional header</i>	<i>0E1</i>	<i>0E2</i>	<i>0E3</i>	
<i>Standard</i>	<i>E1</i>	<i>E2</i>	<i>E3</i>	<i>SCSI ID</i>
	Out	Out	Out	0
	In	Out	Out	1
	Out	In	Out	2
	In	In	Out	3
	Out	Out	In	4
	In	Out	In	5
	Out	In	In	6
	In	In	In	7

Note: When controlling the SCSI ID remotely, In = Ground or TTL Low and Out = Open or TTL High. The odd numbered pins (lower row) are grounded and the even numbered pins carry the signal.

Disabling Spin-Up at Power On - CFP2107S

A jumper in the E5 location, disables spin up after power-on for applications where spin up sequencing is necessary. Disabling spin up on application of power can also be enabled by setting the DSPN bit in MODE SELECT page 00_H (Vendor Specific Parameters). The Host must issue a START UNIT command to cause the drive to spin up. Refer to the Eleventh Generation SCSI Technical Reference Manual for additional information regarding the MODE SELECT and START/STOP UNIT commands. Refer to Figure 4-3 for the location of the Disable Spin jumper, E5 or 0E5.

Table 4-8
Disabling Spin Up at Power-On

<i>E5</i>	<i>DSPN</i>	<i>Result</i>
In	0	Spin Disabled
In	1	Spin Disabled
Out	0	Spin up on Power On
Out	1	Spin Disabled

Note: In = Ground or TTL Low and Out = Open or TTL High. The odd numbered pin is grounded and the even numbered pin carries the signal.

Delaying Spin Up at Power On - CFP2107S

A jumper in the E6 location, delays spin up on power-up by the value of the drive's SCSI ID multiplied by 4 seconds (i.e. SCSI ID 4 will delay 16 seconds). Delaying spin up on application of power can also be enabled by setting the SDLY bit in MODE SELECT page 00_H (Vendor Specific Parameters). Refer to the Eleventh Generation SCSI Technical Reference Manual for additional information regarding the MODE SELECT command. Refer to Figure 4-3 for the location of the Delayed Spin jumper, E6.

Table 4-9
Delaying Spin Up at Power On

<i>E6</i>	<i>SDLY</i>	<i>Result</i>
In	0	Spin Delayed
In	1	Spin Delayed
Out	0	Spin up on Power On
Out	1	Spin Delayed

Note: In = Ground or TTL Low and Out = Open or TTL High. The odd numbered pin is grounded and the even numbered pin carries the signal.

Disabling the SCSI Bus Parity - CFP2107S

SCSI parity is always enabled in both directions, unless the E7 Parity disable jumper is installed. Installing the jumper will cause the drive to ignore SCSI bus Parity In but it will continue to generate SCSI bus Parity Out.

Disabling SCSI Bus Terminator Power (TERMPWR) - CFP2107S

Power to the on-board terminators is provided by the higher of the voltage supplied at Pin #26, J2 or the voltage level at the 5 Volt power input to the drive minus one diode drop. Termination Power to external terminators can be supplied by the drive through Pin #26, J2. The signal output characteristics are described in chapter 5. The TERMPWR line can be disconnected from the drive by removing Jumper E8.

Table 4-10
Disabling SCSI Bus TERMPWR

Jumper E8	Result
In	TERMPWR (J2, Pin #26) connected to the drive's internal termination power.
Out	TERMPWR (J2, Pin #26) open circuit.

Setting the Bus Termination - CFP2107S

This drive provides on-board Alternative 2 active termination for the SCSI bus. The termination resistors, which are contained in two Single Inline Packs (SIPs) should be removed from the drive unless it is a SCSI device at the physical end of the bus. Figure 4-4 shows the location of the terminator resistors.

Figure 4-4
Terminator Resistor Locations

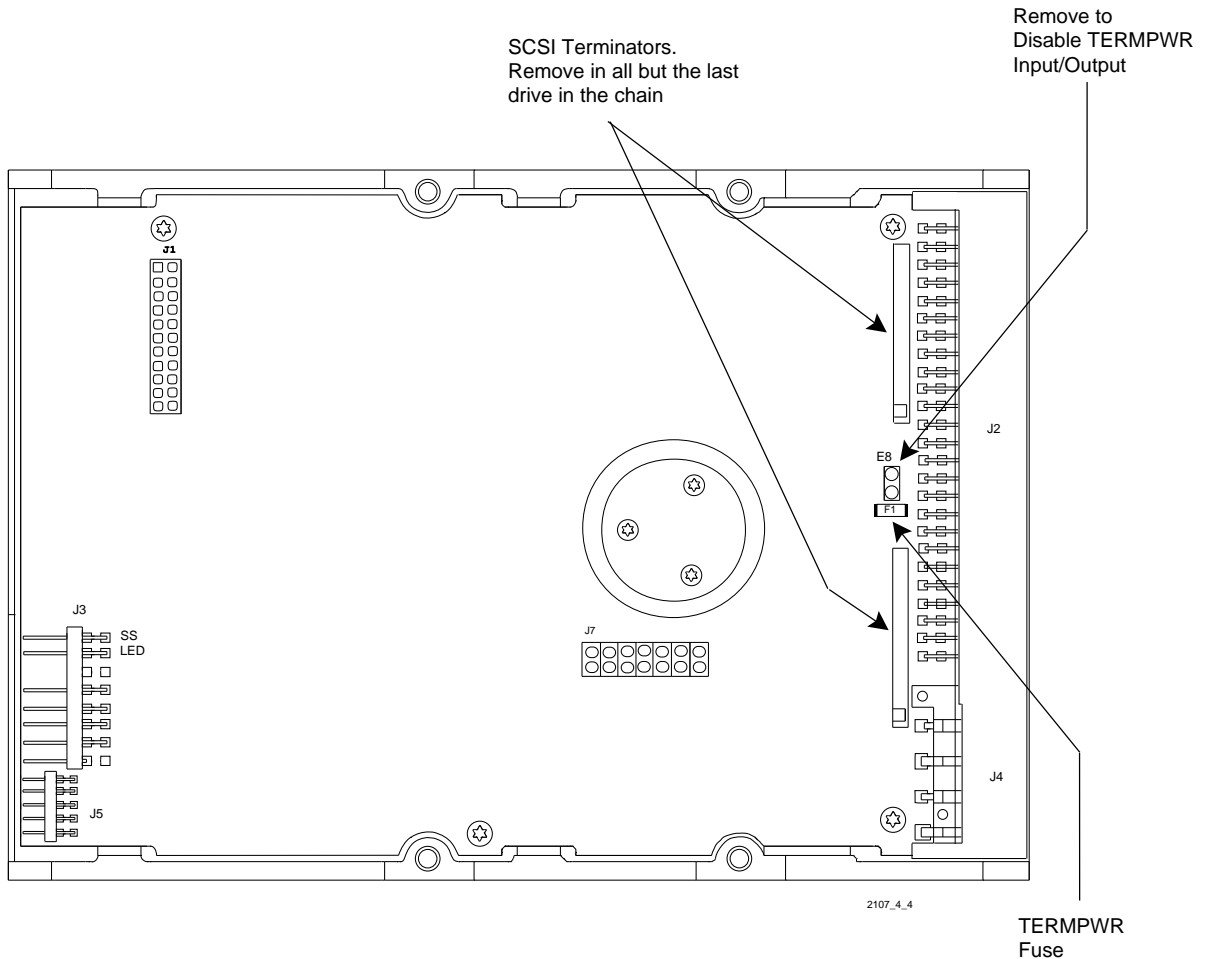

NOTE: The TERMPWR output of the drive is protected by a 1 Ampere fuse. If external terminators are being powered from the drive and SCSI bus problems are suspected, verify that the fuse is still operational using a meter.

Cabling the Drive - CFP2107S

Connect the SCSI interface cable and the spindle synchronization cable (when needed) as shown in Figure 4-5.

Figure 4-5
Connecting the cabling

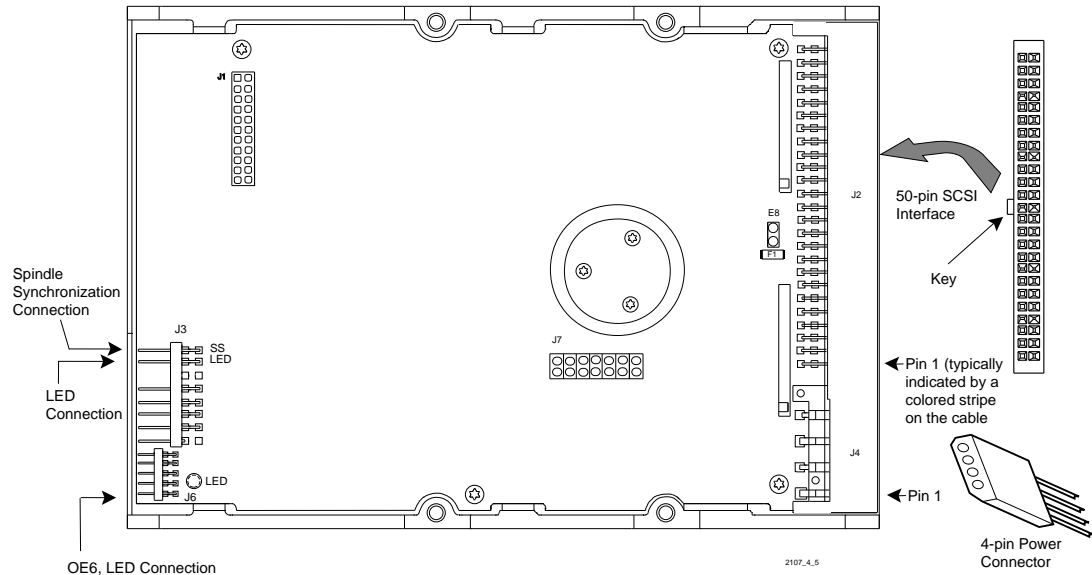

SCSI Bus Cable

The cable and mating connector required to connect the drive to the SCSI bus are described in Chapter 5. In addition, the cable should meet the following guidelines, particularly with FAST SCSI-2 systems:

- Do not route the data cable next to the drive PCB or any other high frequency or large current switching signals. Improper drive operation can result from improper cable routing.
- Cable stubs should not exceed 0.1 meter (4 inches).
- There should be 0.3 meters (12 inches) of cable between drives.
- The total cable length should not exceed 6 meters (20 feet) and may have to be reduced if a mixture of round and flat cable are used.
- Do not tightly bundle excess flat cable against each other since this promotes cross coupling of signals on the cable. Use spacers to maintain a minimum of 0.050 inches (1.27mm) gap between cable runs.
- Do not clamp the cable tightly against a metal chassis since this will degrade the signal. Use spacers or a non-flammable insulation material to maintain a gap between the chassis and the cable.

Spindle Synchronization

The spindle rotation of up to 35 drives may be synchronized together by daisy chaining pin 1 to pin 1 and pin 2 to pin 2 on connector J3. Spindle Synchronization is enabled by setting the appropriate bits in the RPL field of Mode Select page 04. Refer to the Eleventh Generation Disk Drive SCSI-2 Interface Manual for a description of the command implementation. The synchronization tolerance is 1%.

Attaching Power to the Drive - CFP2107S

The drive has a 4-pin DC power connector, J4 mounted on the PCB. The recommended mating connector is AMP part number 1-480424-0 utilizing AMP pins, part number 350078-4 or equivalent.

Connect the DC Power cable to the drive as shown in Figure 4-5.

Attaching a Remote LED - CFP2107S

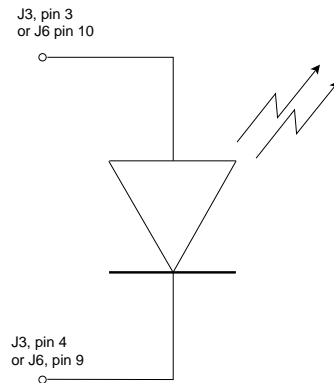

A remote LED can be attached using a 0.1 inch center, 2-pin connector to pins 3 and 4 of J3. The anode of the LED should be connected to pin 3 and the cathode to pin 4.

An external LED can optionally be attached using a 2mm center connector on J6, pins 9 and 10 (location OE6). The anode of the LED should be connected to pin 10 and the cathode to pin 9.

The external LED is connected in parallel to the on board LED and is powered through a 200 ohm current limiting resistor to the +5 volt power.

Mounting the Drive - CFP2107S

The drive is designed to be used in applications where the unit may experience shock and vibrations at greater levels than larger and heavier disk drives will tolerate.

The design features which allow greater shock tolerance are the use of rugged heads and media, a dedicated landing zone, closed loop servo positioning and specially designed motor and actuator assemblies.

Mounting Screw Holes

Six side, or four bottom base mounting points are provided to the customer. The drive is mounted using 6-32 UNC -2B X 0.16 maximum insertion length screws. Refer to Figure 2-3 in Chapter 2 for the location of the mounting holes. The drive may be mounted in any orientation.

Cooling

The enclosure design for the drive must provide adequate provision for removing heat generated by the drive via conduction or air flow convection cooling. The maximum operating temperature for the drive is 55°C. A temperature sensor

mounted on the drive at the location shown below should remain at or below 55°C while the drive(s) are operated at the worst case condition.

The enclosure design should allow air flow above and below the drive to cool both the HDA and printed circuit board assembly. The drive(s) should be positioned in the path of least resistance to the flow of air so that the flow is not routed around the drive. Placing the drive at the source of the shortest air flow path helps to ensure adequate air flow and avoids pre-heating of the air by other heat generating sources.

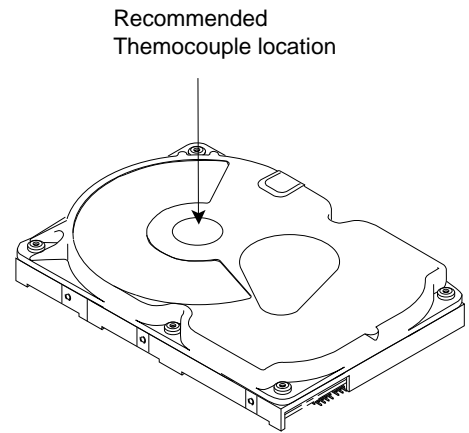

Installing a CFP2107W

Setting the Drive's Jumpers - CFP2107W

Figure 4-6 shows you where to access the drive's jumpers.

Figure 4-6
Jumper Locations

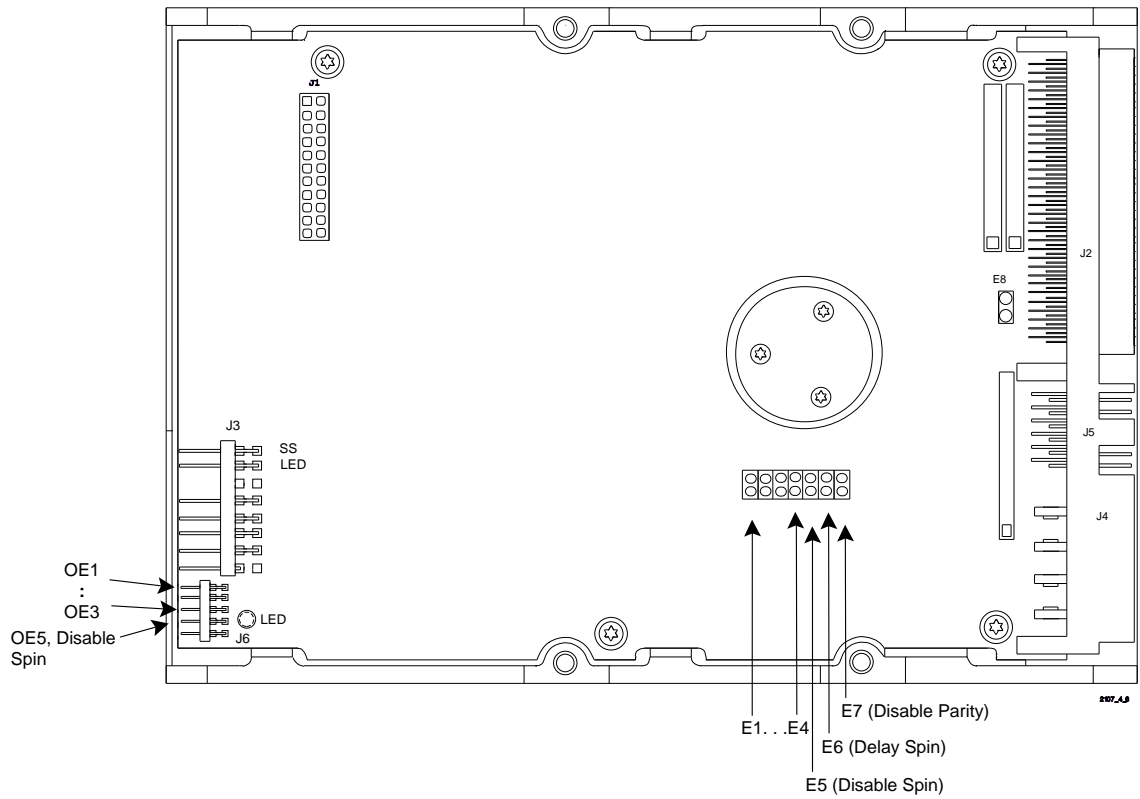

Setting the SCSI Bus Address - CFP2107W

There are four jumpers available for configuration of the SCSI ID: E1, E2, E3 and E4.

The 68-pin unified connector includes a standard 2mm pitch auxiliary header which includes pins to allow remote selection of SCSI IDs. A receptacle connector Amp P/N 1-111623-7 or equivalent can be used to connect a ribbon cable to this header.

Table 4-11 defines the relationship between the jumpers or the pins on J5 and the SCSI ID:

Table 4-11
Setting the SCSI ID

SCSI ID	E1 / Pin 1	E2 / Pin 3	E3 / Pin 5	E4 / Pin 7
0	Out/Open	Out/Open	Out/Open	Out/Open
1	In/Ground	Out/Open	Out/Open	Out/Open
2	Out/Open	In/Ground	Out/Open	Out/Open
3	In/Ground	In/Ground	Out/Open	Out/Open
4	Out/Open	Out/Open	In/Ground	Out/Open
5	In/Ground	Out/Open	In/Ground	Out/Open
6	Out/Open	In/Ground	In/Ground	Out/Open
7	In/Ground	In/Ground	In/Ground	Out/Open
8	Out/Open	Out/Open	Out/Open	In/Ground
9	In/Ground	Out/Open	Out/Open	In/Ground
10	Out/Open	In/Ground	Out/Open	In/Ground
11	In/Ground	In/Ground	Out/Open	In/Ground
12	Out/Open	Out/Open	In/Ground	In/Ground
13	In/Ground	Out/Open	In/Ground	In/Ground
14	Out/Open	In/Ground	In/Ground	In/Ground
15	In/Ground	In/Ground	In/Ground	In/Ground

Note: Open means open circuit or high impedance. Ground means TTL logic low or logic ground. The odd numbered pins (lower row) are grounded and the even numbered pins carry the signal.

Disabling Spin-Up at Power On - CFP2107W

A jumper in the E5 location, disables spin up on power-on for applications where spin up sequencing is necessary. Disabling spin up on application of power can also be enabled by setting the DSPN bit in MODE SELECT page 00_H (Vendor Specific Parameters). The Host must issue a START UNIT command to cause the drive to spin up. Refer to the Eleventh Generation SCSI Technical Reference Manual for additional information regarding the MODE SELECT and START/STOP UNIT commands. Refer to Figure 4-6 for the location of the Disable Spin jumper E5 and the option header.

Table 4-12
Disabling Spin Up at Power On

<i>E5</i>	<i>DSPN</i>	<i>Result</i>
In	0	Spin Disabled
In	1	Spin Disabled
Out	0	Spin up on Power On
Out	1	Spin Disabled

Note: In = Ground or TTL Low and Out = Open or TTL High. The odd numbered pin is grounded and the even numbered pin carries the signal.

Delaying Spin Up at Power On - CFP2107W

A jumper in the E6 location, delays spin up on power-up by the value of the drive's SCSI ID multiplied by 4 seconds (i.e. SCSI ID 4 will delay 16 seconds). Delaying spin up on application of power can also be enabled by setting the SDLY bit in MODE SELECT page 00_H (Vendor Specific Parameters). Refer to the Eleventh Generation SCSI Technical Reference Manual for additional information regarding the MODE SELECT command. Refer to Figure 4-6 for the location of the Delayed Spin jumper, E6.

Table 4-13
Delaying Spin Up at Power On

<i>E6</i>	<i>SDLY</i>	<i>Result</i>
In	0	Spin Delayed
In	1	Spin Delayed
Out	0	Spin up on Power On
Out	1	Spin Delayed

Note: In = Ground or TTL Low and Out = Open or TTL High. The odd numbered pin is grounded and the even numbered pin carries the signal.

Disabling the SCSI Bus Parity - CFP2107W

SCSI parity is always enabled in both directions, unless the E7 Parity disable jumper is installed. Setting the jumper will cause the drive to ignore SCSI bus parity in but it will continue to generate SCSI bus parity out.

Disabling SCSI Bus Terminator Power (TERMPWR) - CFP2107W

Power to the on-board terminators is provided by the higher of the voltage supplied at Pins #17, 18, 51 & 52, J2 or the voltage level at the 5 Volt power input to the drive minus one diode drop. Termination Power to external terminators can be supplied by the drive through Pins #17, 18, 51 & 52, J2. The signal output characteristics are described in chapter 5. The TERMPWR line can be disconnected from the drive by removing Jumper E8.

Table 4-14
Disabling SCSI Bus TERMPWR

Jumper E8	Result
In	TERMPWR (J2, Pins #17, 18, 51 & 52) connected to the drive's internal termination power.
Out	TERMPWR (J2, Pins #17, 18, 51 & 52) open circuit.

Using the J5 Auxiliary Connector

External logic cabled to the J5 connector may be used to control certain characteristics of the drive or access signals.

Table 5-15
J5 Auxiliary Connector Signal Definitions

Pin Number	Signal Name	Pin Number	Signal Name
1	- SEL0	2	- XTFALT
3	- SEL1	4	- VUNIQ
5	- SEL2	6	- SPSYNC
7	- SEL3	8	- XTACTV
9	- ENTERM	10	- GROUND
11	+5V	12	- FAULT

- SEL0

Bit 0 of the binary coded SCSI ID selection input. This signal has a value of 0 when it is negated and a value of 1 when it is asserted for the purpose of selection or arbitration.

This signal is latched within 250 msec of the application of valid power to the drive or optionally the negation of -RST.

If SCSI ID SEL0 is intended to be selected, the host must provide a low impedance connection from - SEL (0) to - XTFALT or to ground, while the ID is being latched, through an appropriate means. Refer to chapter 5 for specific electrical characteristics of these signals.

- XTFALT

This signal is intended to drive an LED to indicate an external fault condition has occurred. This signal is held asserted following the application of power or optionally the negation of -RST during initialization while the SCSI ID is being read. This signal is not supported but meets the requirement of negating the signal while the ID is being read.

- SEL1

Bit 1 of the binary coded SCSI ID selection input. This signal has a value of 0 when it is negated and a value of 2 when it is asserted for the purpose of selection or arbitration.

This signal is latched within 250 msec of the application of valid power to the drive or optionally the negation of -RST.

If SCSI ID SEL 1 is intended to be selected, the host must provide a low impedance connection from - SEL1 to - VUNIQ or to ground, while the ID is being latched, through an appropriate means. Refer to chapter 5 for specific electrical characteristics of these signals.

- VUNIQ

This signal is an open-collector output available for Vendor Unique usage. This signal is not supported but meets the requirement of negating the signal while the ID is being read.

- SEL2

Bit 2 of the binary coded SCSI ID selection input. This signal has a value of 0 when it is negated and a value of 4 when it is asserted for the purpose of selection or arbitration.

This signal is latched within 250 msec of the application of valid power to the drive or optionally the negation of -RST.

If SCSI ID SEL2 is intended, to be selected, the host must provide a low impedance connection from - SEL2 to - SPSYNC or to ground, while the ID is being latched, through an appropriate means. Refer to chapter 5 for specific electrical characteristics of these signals.

- SPSYNC

This signal used to provide a spindle rotation synchronization reference. The pins for all of the drives which are to be synchronized must be connected together. The drives must be of like model to operate. The spindles are synchronized using a "floating master" concept, where the drives will synchronize to the first drive to reach full speed. The synchronization tolerance is 1%.

This signal meets the requirement of negating the signal while the ID is being read.

- SEL3

Bit 3 of the binary coded SCSI ID selection input. This signal has a value of 0 when it is negated and a value of 8 when it is asserted for the purpose of selection or arbitration.

This signal is latched within 250 msec of the application of valid power to the drive or optionally the negation of -RST.

If SCSI ID SEL3 is intended, to be selected, the host must provide a low impedance connection from - SEL3 to - XTACTV or to ground, while the ID is being latched, through an appropriate means. Refer to chapter 5 for specific electrical characteristics of these signals.

- XTACTV

This signal is an open collector output intended to drive an LED to indicate the device is active. This signal is negated while the SCSI ID is being read.

- GROUND

This signal is connected to the drive's logic ground.

+5 Volts

This signal provides 5 volts of DC power to drive LEDs and is current limited by a 120 ohm resistor.

- FAULT

The assertion of this signal will cause the drive to stop any media-altering activity, which may result in the drive asserting -XTFALT or -VUNIQ, or both. This signal is intended to be used as a power failure warning and/or as a write protect input. This signal is not supported by this drive.

Setting the Bus Termination - CFP2107W

This drive provides on board Alternative 2 active termination for the SCSI bus. The termination resistors, which are contained in three Single Inline Packs (SIPs) should be removed from the drive unless it is a SCSI device at the physical end of the bus. Figure 4-7 shows the location of the terminator resistors.

Figure 4-7
Terminator Resistor Locations

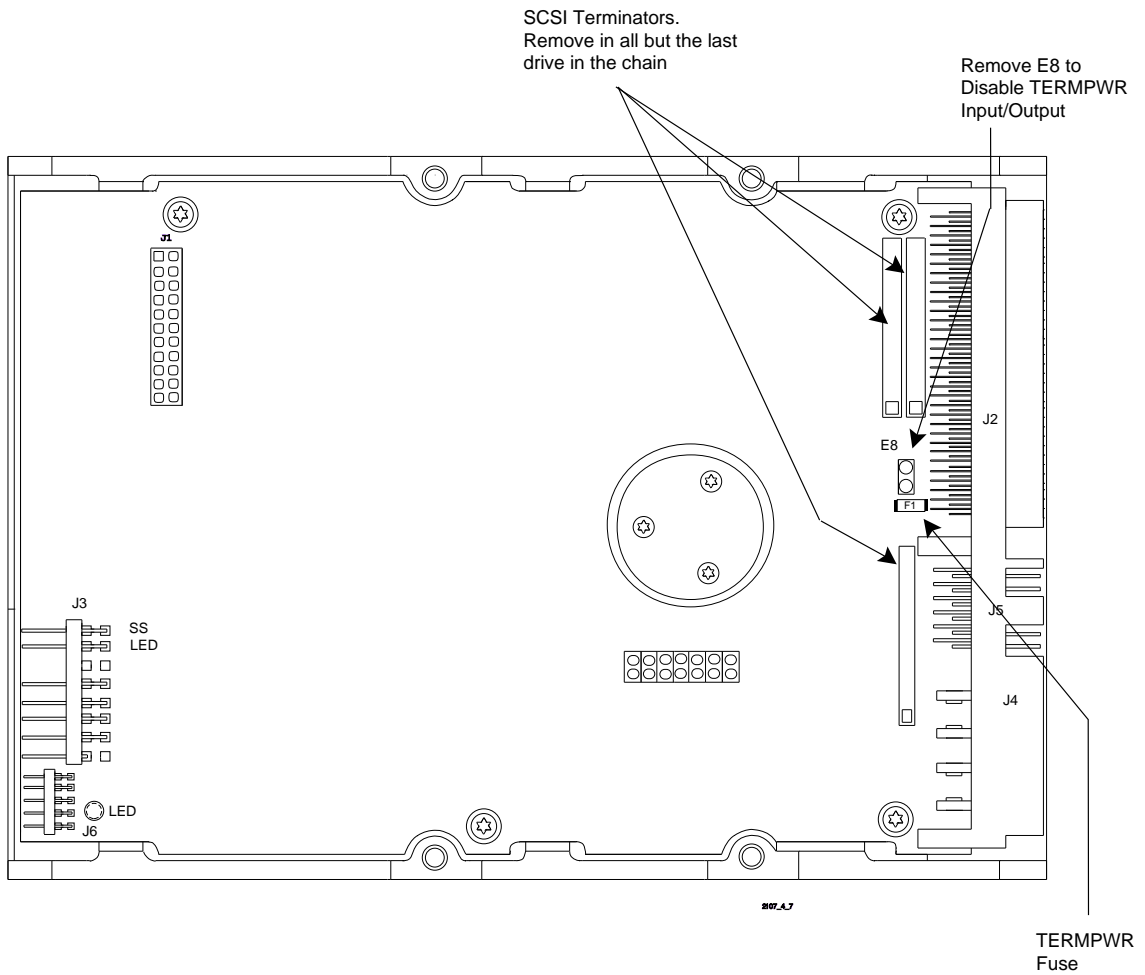

Cabling the Drive - CFP2107W

Connect the SCSI interface cable and the spindle synchronization cable (when needed) as shown in Figure 4-8.

Figure 4-8
Connecting the cabling

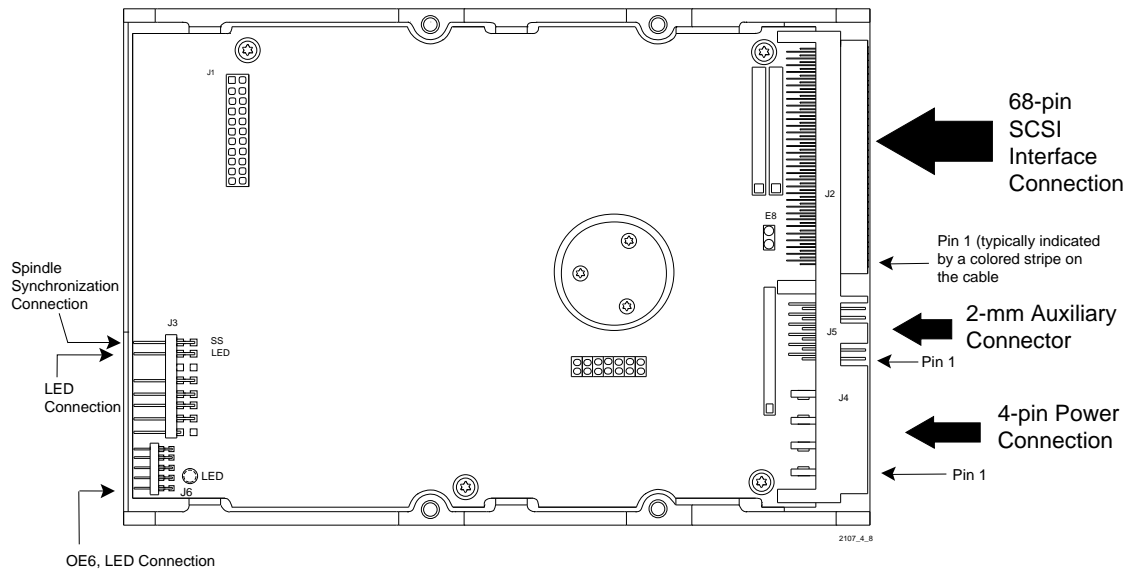

SCSI Bus Cable

The cable and mating connector required to connect the drive to the SCSI bus are described in Chapter 5. In addition, the cable should meet the following guidelines, particularly with FAST SCSI-2 systems:

- Do not route the data cable next to the drive PCB or any other high frequency or large current switching signals. Improper drive operation can result from improper cable routing.
- Cable stubs should not exceed 0.1 meter (4 inches).
- There should be 0.3 meters (12 inches) of cable between drives.
- The total cable length should not exceed 3 meters (10 feet) and may have to be reduced if a mixture of round and flat cable are used.
- Do not tightly bundle excess flat cable against each other since this promotes cross coupling of signals on the cable. Use spacers to maintain a minimum of 0.050 inches (1.27mm) gap between cable runs.
- Do not clamp the cable tightly against a metal chassis since this will degrade the signal. Use spacers or a non-flammable insulation material to maintain a gap between the chassis and the cable.

Mixing Wide and Narrow SCSI Devices on a SCSI Bus

It may sometimes be desirable to attach Narrow SCSI devices such as tape backup devices or CDROMs to the same SCSI Host Bus Adapter being used to control Wide SCSI devices, such as the CFP2107W. Intermixing of both Wide and Narrow SCSI devices on the same bus requires special considerations:

- The Narrow SCSI devices must be placed at the physical end of the bus
- The high byte of the SCSI data bus must be terminated at the transition adapter from the 34-pair wire to the 25-pair wire. Figure 4-9 shows the interconnection.
- The cable impedance of the 34-pair wire and the 25-pair wire should be as closely matched as possible.
- The 68-pair cable with 30 AWG wire uses four wires to carry TERMPWR, which must be joined to wire 26 of the 25-pair wire, if terminator power has to be carried over the cable.

Figure 4-9
Wide-to-Narrow Adapter

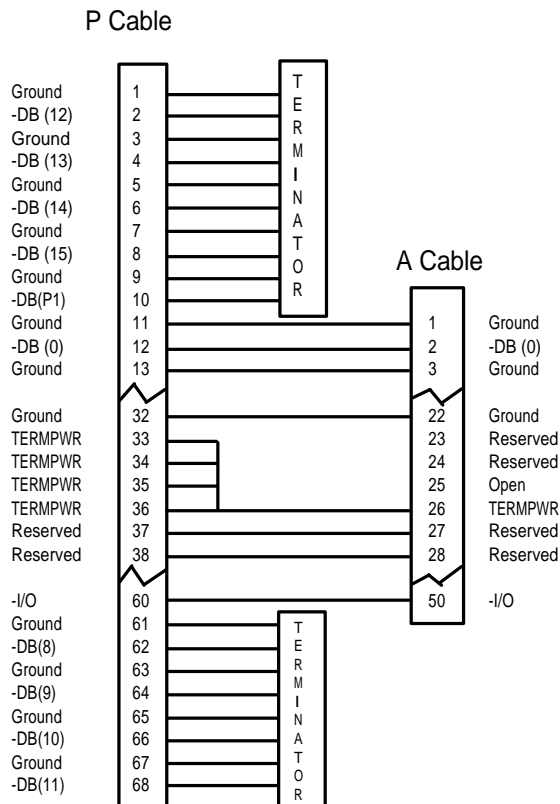

Spindle Synchronization

The spindle rotation of up to 35 drives may be synchronized together by daisy chaining pin 1 to pin 1 and pin 2 to pin 2 on connector J3. Spindle Synchronization is enabled by setting the appropriate bits in the RPL field of Mode Select page 04. Refer to the Eleventh Generation Disk Drive SCSI-2 Interface Manual for a description of the command implementation. The synchronization tolerance is 1%.

Attaching Power to the Drive - CFP2107W

The drive has a 4-pin DC power connector, J4, which is part of the Unified Connector, mounted on the PCB. The recommended mating connector is AMP part number 1-480424-0 utilizing AMP pins, part number 350078-4 or equivalent.

Attaching a Remote LED - CFP2107W

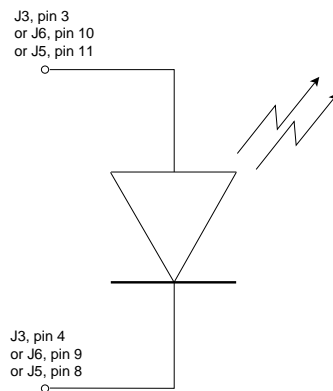

A remote LED can be attached using a 0.1 inch center, 2-pin connector to pins 3 and 4 of J3. The anode of the LED should be connected to pin 3 and the cathode to pin 4.

An external LED can optionally be attached using a 2mm center connector on J6, pins 9 and 10 (location OE6). The anode of the LED should be connected to pin 10 and the cathode to pin 9.

An external LED on J3 or J6 is connected in parallel to the on board LED and is powered through a 200 ohm current limiting resistor to the +5 volt power.

A third option is available on J5, which is between the 68-pin SCSI interface and the 4-pin power input on the unified connector. The anode can be connected to pin 11, which is connected to +5 volts through a 120 ohm current limiting resistor or an external current limited voltage source. The cathode is connected to pin 8.

Mounting the Drive - CFP2107W

The drive is designed to be used in applications where the unit may experience shock and vibrations at greater levels than larger and heavier disk drives will tolerate.

The design features which allow greater shock tolerance are the use of rugged heads and media, a dedicated landing zone, closed loop servo positioning and specially designed motor and actuator assemblies.

Mounting Screw Holes

Six side, or four bottom base mounting points are provided to the customer. The drive is mounted using 6-32 UNC -2B X 0.16 maximum insertion length screws. Refer to Figure 2-4 in Chapter 2 for the location of the mounting holes. The drive may be mounted in any orientation.

Cooling

The enclosure design for the drive must provide adequate provision for removing heat generated by the drive via conduction or air flow convection cooling. The maximum operating temperature for the drive is 55°C. A temperature sensor mounted on the drive at the location shown below should remain at or below 55°C while the drive(s) are operated at the worst case condition.

The enclosure design should allow air flow above and below the drive to cool both the HDA and printed circuit board assembly. The drive(s) should be positioned in the path of least resistance to the flow of air so that the flow is not routed around the drive. Placing the drive at the source of the shortest air flow path helps to ensure adequate air flow and avoids pre-heating of the air by other heat generating sources.

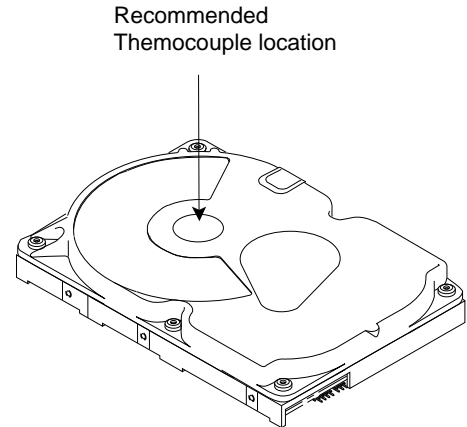

Electrical Description

The paragraphs which follow describe the input and output electrical characteristics of the drive.

Output Characteristics

The output drivers for Data, Parity, REQ and ACK are optionally active negation. When they are set for active negation, they have three states: asserted, negated and high impedance. The remainder of the signals have open collector (drain) outputs. The drivers maintain a high impedance state during power-on and power-off cycles. The driven signals have the following output characteristics when measured at the drive connector:

Table 5-1
Active Negation Driver Output Signal Characteristics

Signal Characteristic	Value
Signal Assertion	0.1 VDC to 0.5 VDC at 48 mA
Minimum Driver Output Capability	48 mA (sinking) at 0.5 VDC
Signal Negation	2.0 VDC to 3.24 VDC at 7 mA 3.0 VDC at 20 mA

Table 5-2
Open Collector Driver Output Signal Characteristics

Signal Characteristic	Value
Signal Assertion	0.0 VDC to 0.5 VDC at 48 mA
Minimum Driver Output Capability	48 mA (sinking) at 0.5 VDC
Signal Negation	2.5 VDC to 5.25 VDC

Input Characteristics

The characteristics of the input receivers and the requirements for each signal received by the drive as measured at the drive connector are shown in table 5-3:

Table 5-3
Drive Input Signal Characteristics

<i>Signal Characteristic</i>	<i>Value</i>
Signal Assertion	0.0 VDC to 0.8 VDC
Signal Negation	2.0 VDC to 5.25 VDC
Input Load (low level)	-20 μ A to 0.0 mA at 0.5 VDC
Input Load (high level)	0.0 mA to 20 μ A at 2.7 VDC

Model-Specific SCSI Physical Characteristics

The sections which follow describe, for each of the drive models, those SCSI characteristics which vary from model to model. These characteristics include:

- Termination
- Cable requirements
- Connector requirements
- Connector Pin assignments
- Interface Timing requirements

CFP2107E (WIDE, 80-pin Single Connector Attachment [SCA])

External Terminator Power

The interface connector carries both power and ground so a separate TERMPWR interface line is not provided.

Internal Termination

This version of the drive has no on-board termination so the drive must be externally terminated. Alternative 2 active termination is recommended. Alternative 1 passive termination is not suitable for this application.

Cable Requirements

This version of the drive is designed to facilitate interfacing directly to a mating connector which is on a passive back plane or directly into a motherboard. The design of the SCSI bus interconnect system should meet the following guidelines, particularly with FAST SCSI-2 systems:

- Do not route the data signals next to any high frequency or large current switching signals. Unreliable drive operation can result from improper signal routing.
- Signal line stubs should not exceed 0.1 meter (4 inches).
- There should be 0.3 meters (12 inches) of transmission line between drives.
- The total length of any signal line should not exceed 6 meters (20 feet) and may have to be reduced if excessive impedance discontinuities exist on the bus.
- Maintain a minimum of 0.050 inches (1.27mm) gap between adjacent signal runs to control crosstalk between signal lines.
- Signals routed over a ground plane or between ground planes have different characteristic impedance. Signals with critical timing like REQ, ACK and Data should be routed similarly.

The signal length between devices should either be spaced shorter than the stub length, which treats a group of devices as a lumped element, or far enough apart that a transmission line exists (0.3 meters or 12 inches). These signal length considerations should include the length of signal traces and connectors on the printed circuit board. The diagram below shows how it is possible to interconnect six 1-inch height drives over a relatively short length of interconnect.

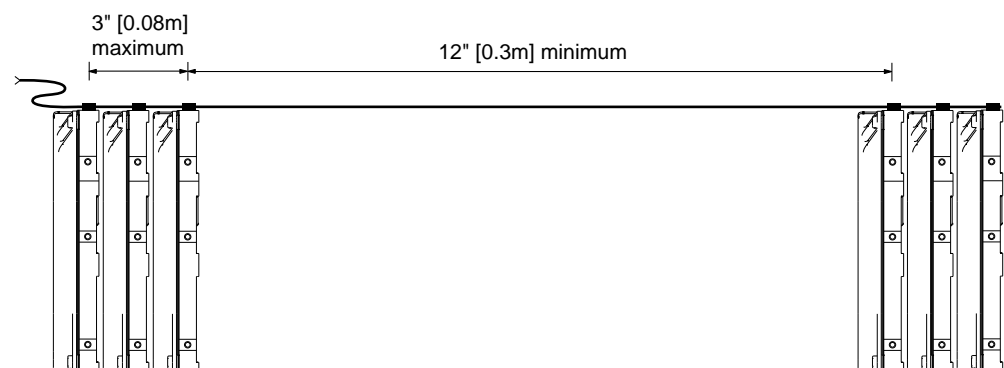

Connector Requirements

The drive's connector will mate with a AMP Champ 2-557103-1 vertical receptacle or the AMP Champ 2-557101-1 right angle receptacle. A mating connector which is compatible with 0.025 inch (0.63 mm) centerline #30 AWG solid PVC insulation cabling is AMP Camp 1-557089-3. Refer to figure 2-1 for the location of the connector on the drive.

Single Connector Attachment (SCA) Signal Definitions

Power

Four +12 Volt signals provide the +12 volt power to the drive. The current return for the +12 volt power is through the +12 Volt Ground signals. The maximum current that can be provided to the drive through the +12 Volt signal pins is 3 Amperes. The supply current and return current must be distributed as evenly as possible among the pins. The maximum current is while the drive motor is starting.

Three +5 Volt signal pins provide +5 volt power to the drive. The current return for the +5 volt power is through the +5 Volt Ground pins. It is expected that the +5 Volt Ground will also establish the digital logic ground for the drive. The maximum current that can be provided to the drive through the +5 Volt signal pins is 2 Amperes. The supply current and return current must be distributed as evenly as possible among the pins.

These specifications refer to the connector's characteristics. Refer to Chapter 2 for the drive's power requirements.

Spindle Sync

The spindle rotation of up to 35 drives may be synchronized together by daisy chaining pin 1 to pin 1 and pin 2 to pin 2 of each drive on connector J3. The synchronization tolerance is 1%.

Table 5-4
Electrical Characteristics for the Spindle Sync Signal

STATE	Current	Voltage
High	$0 < I_{IH} < 20 \mu\text{A}$	$2.5 \text{ V} < V_{IH} < V_{CC} + 0.3 \text{ V}$
Low	$0 < I_{OH} < -48 \text{ mA}$	$-0.1 \text{ V} < V_{IL} < 0.4 \text{ V}$

LED Out

The LED out signal is driven by the drive when the drive is performing a SCSI operation. The LED out signal is designed to pull down the cathode of an LED. The anode is attached to the proper +5 volt supply through an appropriate current limiting resistor. The LED and the current limiting resistor are external to the drive.

Table 5-5

Output Characteristics of the LED Driver Signal

State	Current Drive Available	Output Voltage
Drive LED Off	$0 < I_{OH} < 100 \mu\text{A}$	
Drive LED On	$I_{OL} < -30 \text{ mA}$	$0 < V_{OL} < 0.8 \text{ Volts}$

Motor Start Controls

Table 5-6
Electrical Characteristics for RMT_START and DLYD_START

State	Current	Voltage
Open	$0 < I_{IH} < \pm 100 \mu\text{A}$	$2.4 \text{ V} < V_{IH} < V_{CC} + 0.5 \text{ V}$
Ground	$0 < I_{OH} < -3 \text{ mA}$	$-0.5 \text{ V} < V_{IL} < 0.4 \text{ V}$

SCSI ID Selection

Table 5-7
Electrical Characteristics for the SCSI ID Signals SCSI ID (0) - (3)

State	Current	Voltage
Open	$0 < I_{IH} < \pm 100 \mu\text{A}$	$2.4 \text{ V} < V_{IH} < V_{CC} + 0.5 \text{ V}$
Ground	$0 < I_{OH} < -3 \text{ mA}$	$-0.5 \text{ V} < V_{IL} < 0.4 \text{ V}$

Interface Pin Assignments

The pin assignments for the interface connector are shown below:

Table 5-8
Interface Signal Definitions

<i>Pin</i>	<i>Signal</i>	<i>Pin</i>	<i>Signal</i>
1	+12 Volt	41	+12 Volt Ground
2	+12 Volt	42	+12 Volt Ground
3	+12 Volt	43	+12 Volt Ground
4	+12 Volt	44	+12 Volt Ground
5	Reserved / NC	45	Reserved / NC
6	Reserved / NC	46	Reserved / NC
7	-DB(11)	47	Ground
8	-DB(10)	48	Ground
9	-DB(9)	49	Ground
10	-DB(8)	50	Ground
11	-I/O	51	Ground
12	-REQ	52	Ground
13	-C/D	53	Ground
14	-SEL	54	Ground
15	-MSG	55	Ground
16	-RST	56	Ground
17	-ACK	57	Ground
18	-BSY	58	Ground
19	-ATN	59	Ground
20	-DB(P0)	60	Ground
21	-DB(7)	61	Ground
22	-DB(6)	62	Ground
23	-DB(5)	63	Ground
24	-DB(4)	64	Ground
25	-DB(3)	65	Ground
26	-DB(2)	66	Ground
27	-DB(1)	67	Ground
28	-DB(0)	68	Ground
29	-DB(P1)	69	Ground
30	-DB(15)	70	Ground
31	-DB(14)	71	Ground
32	-DB(13)	72	Ground
33	-DB(12)	73	Ground
34	+5 Volt	74	+5 Volt Ground
35	+5 Volt	75	+5 Volt Ground
36	+5 Volt	76	+5 Volt Ground
37	SYNC	77	LED
38	RMT_START	78	DLYD_START
39	SCSI ID (0)	79	SCSI ID (1)
40	SCSI ID (2)	80	SCSI ID (3)

Notes:

1. The minus sign (-) indicates active low.
2. Pins marked Reserved are not connected.

Interface Timing Requirements

Unless otherwise noted, the delay-time measurements are calculated from signal conditions existing at the drive's own SCSI bus connector. Normally these measurements (except cable skew delay) can be made without considering delays in the inter-connect system.

Table 5-9
SCSI Bus Timing Values

Timing Description	Timing Value		
	fast	slow	asynch
Arbitration Delay	2.4 μ s	2.4 μ s	2.4 μ s
Bus Clear Delay	800 ns	800 ns	800 ns
Bus Free Delay	800 ns	800 ns	800 ns
Bus Set Delay	1.8 μ s	1.8 μ s	1.8 μ s
Bus Settle Delay	400 ns	400 ns	400 ns
Cable Skew Delay ¹	4 ns	4 ns	4 ns
Data Release Delay	400 ns	400 ns	400 ns
Receive Assertion Period	22 ns	70 ns	n/a
Receive Hold Time	25 ns	25 ns	n/a
Receive Negation Period	22 ns	70 ns	n/a
Receive Setup Time	15 ns	15 ns	n/a
Reset Hold Time	25 μ s	25 μ s	25 μ s
Selection Abort Time	200 μ s	200 μ s	200 μ s
Selection Time-out Delay ²	250 ms	250 ms	250 ms
System Deskew Delay	20 ns	45 ns	45 ns
Transmit Assertion Period	30 ns	80 ns	n/a
Transmit Hold Time	33 ns	53 ns	n/a
Transmit Negation Period	30 ns	80 ns	n/a
Transmit Setup Time	23 ns	23 ns	n/a

Notes:

¹ This time does not apply at the SCSI connector of the drive.

² This is a recommended time. It is not mandatory.

Model CFP2107S (Narrow, 50-pin SCSI)

External Terminator Power

Power to the on-board terminators is provided by the higher of the voltage supplied at Pin #26, J2 or the voltage level at the 5 Volt power input to the drive minus one diode drop. The diode prevents back flow of current to the drive. Termination Power to external terminators can be supplied by the drive through Pin #26, J2. The TERMPWR line can be disconnected from the drive by removing Jumper E8. Table 5-10 describes the electrical characteristics of the TERMPWR line when it is used to supply power to an external terminator. Table 5-11 describes the required electrical characteristics for any external source of termination power.

Table 5-10
TERMPWR Output Electrical Characteristics

Signal Characteristic	Value
Supply voltage	4.06 VDC to 4.56 VDC
Minimum source capability:	800 mA (fused at 1000 mA)

Table 5-11
TERMPWR Input Electrical Characteristics

Signal Characteristic	Value
Input voltage	4.00 VDC to 5.25 VDC
Minimum source capability:	1000 mA (fused at 1000 mA)
Sink current:	1.0 mA maximum, excluding power to the internal terminator.

Internal Termination

This drive provides on-board Alternative 2 active termination for the SCSI bus. The termination resistors, which are contained in two Single Inline Packs (SIPs) should be removed from the drive unless it is a SCSI device at a physical end of the bus. The terminator equivalent circuit is shown below for reference:

Figure 5-1
Terminator Equivalent Circuit

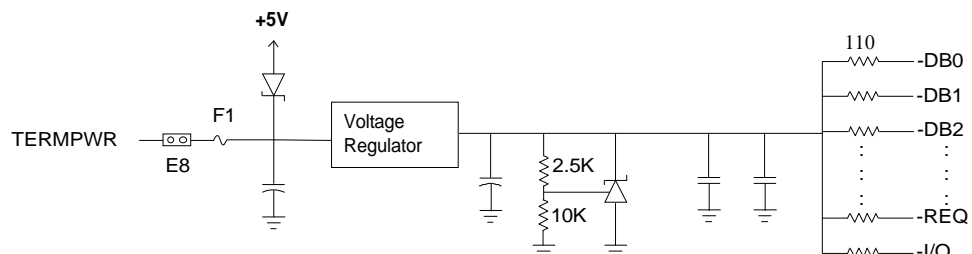

Cable Requirements

A 50 conductor cable no more than 6 meters (19.68 feet) cumulative length with at least 28 AWG wire size and a characteristic impedance of 70 to 100 ohms (84 ohms nominal) is required. In systems which use the fast synchronous transfer option, the cable should meet the following additional requirements:

Table 5-12
Interface Cable Electrical Characteristics

Specification	Value
Signal Attenuation	0.095dB maximum per meter at 5 Mhz
Pair-to-Pair Propagation Delay Delta	0.20 ns maximum per meter
DC Resistance	0.230 ohms maximum per meter at 20° C

Connector Requirements

The connector on the drive is a 50-position header which consists of 2 rows of 25 male pins on 0.100 inch centers. The mating connector is a SCSI-2 Non-shielded Alternative 1, A-cable connector which is shown below:

Figure 5-2
A-Cable Connector

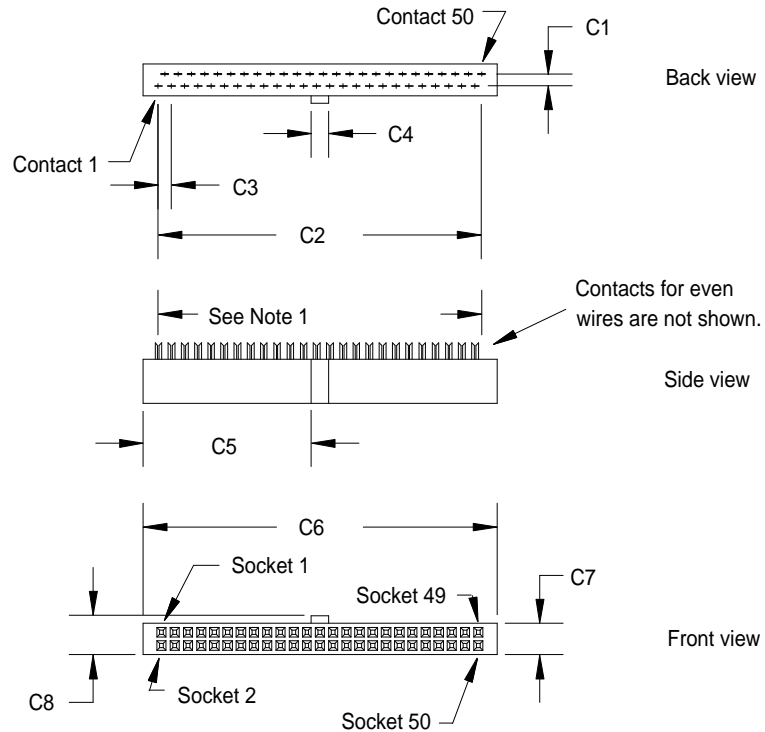

Dimensions	Millimeters	Inches	Notes:
C1	2.540	0.100	(1) Fifty contacts on 1.27mm (0.05 inch) staggered spacing = 62.23mm (2.450 inch) [ref.] (2) Tolerances +0.127mm (0.005 inch) noncumulative unless specified otherwise. (3) Connector cover and strain relief are optional
C2	60.960	2.400	
C3	2.540	0.100	
C4	3.302	0.130	
C5	32.385	1.275	
C6	68.072	2.680	
C7	6.096	0.240	
C8	7.620	0.300	

Interface Pin Assignments

The pin assignments for the interface connector are shown below:

Table 5-13
Interface Signal Definitions

Pin	Signal	Pin	Signal
01	GND	02	-DB0
03	GND	04	-DB1
05	GND	06	-DB2
07	GND	08	-DB3
09	GND	10	-DB4
11	GND	12	-DB5
13	GND	14	-DB6
15	GND	16	-DB7
17	GND	18	-DBP
19	GND	20	GND
21	GND	22	GND
23	RESERVED	24	RESERVED
25	OPEN	26	TERMPWR
27	RESERVED	28	RESERVED
29	GND	30	GND
31	GND	32	-ATN
33	GND	34	GND
35	GND	36	-BSY
37	GND	38	-ACK
39	GND	40	-RST
41	GND	42	-MSG
43	GND	44	-SEL
45	GND	46	-C/D
47	GND	48	-REQ
49	GND	50	-I/O

Notes:

1. The minus sign (-) indicates active low.
2. All odd pins except pin 25 must be connected to ground. Pin 25 is left open.
3. Pins marked Reserved are connected to ground.

Interface Timing Requirements

Unless otherwise noted, the delay-time measurements are calculated from signal conditions existing at the drive's own SCSI bus connector. Normally these measurements (except cable skew delay) can be made without considering delays in the cable.

Table 5-14
SCSI Bus Timing Values

Timing Description	Timing Value		
	fast	slow	asynch
Arbitration Delay	2.4 μ s	2.4 μ s	2.4 μ s
Bus Clear Delay	800 ns	800 ns	800 ns
Bus Free Delay	800 ns	800 ns	800 ns
Bus Set Delay	1.8 μ s	1.8 μ s	1.8 μ s
Bus Settle Delay	400 ns	400 ns	400 ns
Cable Skew Delay ¹	4 ns	4 ns	4 ns
Data Release Delay	400 ns	400 ns	400 ns
Receive Assertion Period	22 ns	70 ns	n/a
Receive Hold Time	25 ns	25 ns	n/a
Receive Negation Period	22 ns	70 ns	n/a
Receive Setup Time	15 ns	15 ns	n/a
Reset Hold Time	25 μ s	25 μ s	25 μ s
Selection Abort Time	200 μ s	200 μ s	200 μ s
Selection Time-out Delay ²	250 ms	250 ms	250 ms
System Deskew Delay	20 ns	45 ns	45 ns
Transmit Assertion Period	30 ns	80 ns	n/a
Transmit Hold Time	33 ns	53 ns	n/a
Transmit Negation Period	30 ns	80 ns	n/a
Transmit Setup Time	23 ns	23 ns	n/a

Notes:

¹ This time does not apply at the SCSI connector of the drive.

² This is a recommended time. It is not mandatory.

Model CFP2107W (Wide, Unitized SCSI-3 P-Connector)

External Terminator Power

Power to the on-board terminators is provided by the higher of the voltage supplied at Pin #17, 18, 51, & 52, J2 or the voltage level at the 5 Volt power input to the drive minus one diode drop. The diode prevents back flow of current to the drive. Termination Power to external terminators can be supplied by the drive through Pin #17, 18, 51, & 52, J2. The TERMPWR line can be disconnected from the drive by removing Jumper E8. Table 5-11 describes the electrical characteristics of the TERMPWR line when it is used to supply power to an external terminator.

Table 5-15
TERMPWR Electrical Output Characteristics

Signal Characteristic	Value
Supply voltage	4.06 VDC to 4.56 VDC (dependent on power supplied to the drive)
Minimum source capability:	1500 mA

Table 5-16
TERMPWR Input Electrical Characteristics

Signal Characteristic	Value
Input voltage	4.00 VDC to 5.25 VDC
Minimum source capability:	1500 mA (fused at 1500 mA)
Sink current:	1.0 mA maximum, excluding power to the internal terminator.

Internal Termination

This drive provides on-board Alternative 2 active termination for the SCSI bus. The termination resistors, which are contained in three Single Inline Packs (SIPs) should be removed from the drive unless it is a SCSI device at a physical end of the bus. The terminator equivalent circuit is shown below for reference:

Figure 5-2
Terminator Equivalent Circuit

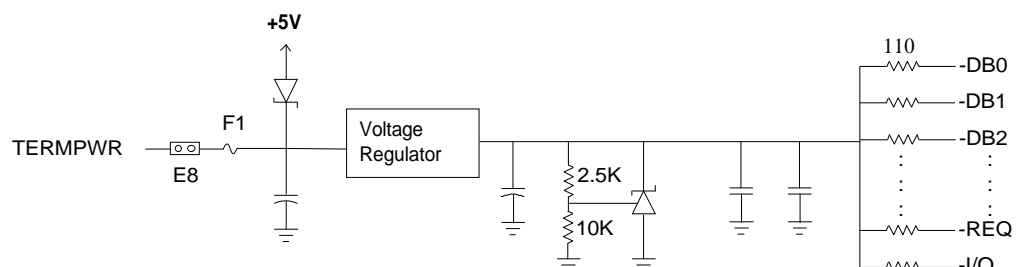

J5 Auxiliary Connector Signal Characteristics

Table 5-17
J5 Auxiliary Interface Electrical Characteristics

State	Current	Voltage
High	$0 < I_{IH} < 20 \mu\text{A}$	$2.5 \text{ V} < V_{IH} < V_{CC} + 0.3 \text{ V}$
Low	$0 < I_{OH} < -48 \text{ mA}$	$-0.1 \text{ V} < V_{IL} < 0.4 \text{ V}$

Cable Requirements

A 68 conductor cable no more than 3 meters (9.84 feet) cumulative length with at least 30 AWG wire size and a characteristic impedance of 70 to 100 ohms (84 ohms nominal) is required. In systems which use the fast synchronous transfer option, the cable should meet the following additional requirements:

Table 5-18
Interface Cable Electrical Characteristics

Specification	Value
Signal Attenuation	0.095dB maximum per meter at 5 Mhz
Pair-to-Pair Propagation Delay Delta	0.20 ns maximum per meter
DC Resistance	0.230 ohms maximum per meter at 20° C

Connector Requirements

The connector on the drive is a 68-pin . The mating connector is a SCSI 3 Non-shielded P-cable connector which is shown below:

**Figure 5-4
P-Cable Connector**

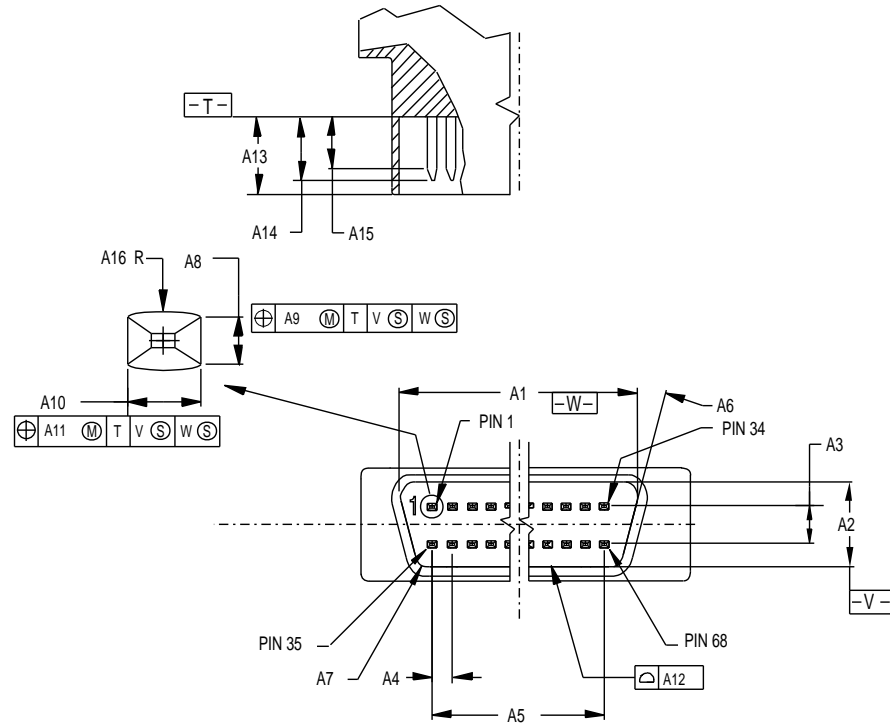

DIMENSIONS	Millimeters	Inches
A1	46.28	1.822
A2	5.69	0.224
A3	2.54	0.100
A4	1.27	0.050
A5	41.91	1.650
A6	15°	15°
A7	1.04 R	0.041 R
A8	0.396 ± 0.010	0.0156 ± 0.0004
A9	0.23	0.009
A10	0.60 ± 0.03	0.024 ± 0.001
A11	0.23	0.009
A12	0.05	0.002
A13	5.15 ± 0.15	0.203 ± 0.006
A14	4.39 MAX	0.173 MAX
A15	3.02 MIN	0.119 MIN
A16	1.02 ± 0.25	0.040 ± 0.010

Interface Pin Assignments

The pin assignments for the interface connector are shown below:

Table 5-19
Interface Signal Definitions

<i>Pin</i>	<i>Signal</i>	<i>Pin</i>	<i>Signal</i>
1	Ground	35	-DB(12)
2	Ground	36	-DB(13)
3	Ground	37	-DB(14)
4	Ground	38	-DB(15)
5	Ground	39	-DB(P1)
6	Ground	40	-DB(0)
7	Ground	41	-DB(1)
8	Ground	42	-DB(2)
9	Ground	43	-DB(3)
10	Ground	44	-DB(4)
11	Ground	45	-DB(5)
12	Ground	46	-DB(6)
13	Ground	47	-DB(7)
14	Ground	48	-DB(P)
15	Ground	49	Ground
16	Ground	50	Ground
17	TERMPWR	51	TERMPWR
18	TERMPWR	52	TERMPWR
19	Reserved	53	Reserved
20	Ground	54	Ground
21	Ground	55	--ATN
22	Ground	56	Ground
23	Ground	57	-BSY
24	Ground	58	-ACK
25	Ground	59	-RST
26	Ground	60	-MSG
27	Ground	61	-SEL
28	Ground	62	-C/D
29	Ground	63	-REQ
30	Ground	64	-I/O
31	Ground	65	-DB(8)
32	Ground	66	-DB(9)
33	Ground	67	-DB(10)
34	Ground	68	-DB(11)

Notes:

1. The minus sign (-) indicates active low.
2. Pins marked Reserved are not connected.

Interface Timing Requirements

Unless otherwise noted, the delay-time measurements are calculated from signal conditions existing at the drive's own SCSI bus connector. Normally these measurements (except cable skew delay) can be made without considering delays in the cable.

Table 5-20
SCSI Bus Timing Values

Timing Description	Timing Value		
	fast	slow	asynch
Arbitration Delay	2.4 μ s	2.4 μ s	2.4 μ s
Bus Clear Delay	800 ns	800 ns	800 ns
Bus Free Delay	800 ns	800 ns	800 ns
Bus Set Delay	1.8 μ s	1.8 μ s	1.8 μ s
Bus Settle Delay	400 ns	400 ns	400 ns
Cable Skew Delay ¹	4 ns	4 ns	4 ns
Data Release Delay	400 ns	400 ns	400 ns
Receive Assertion Period	22 ns	70 ns	n/a
Receive Hold Time	25 ns	25 ns	n/a
Receive Negation Period	22 ns	70 ns	n/a
Receive Setup Time	15 ns	15 ns	n/a
Reset Hold Time	25 μ s	25 μ s	25 μ s
Selection Abort Time	200 μ s	200 μ s	200 μ s
Selection Time-out Delay ²	250 ms	250 ms	250 ms
System Deskew Delay	20 ns	45 ns	45 ns
Transmit Assertion Period	30 ns	80 ns	n/a
Transmit Hold Time	33 ns	53 ns	n/a
Transmit Negation Period	30 ns	80 ns	n/a
Transmit Setup Time	23 ns	23 ns	n/a

Notes:

¹ This time does not apply at the SCSI connector of the drive.

² This is a recommended time. It is not mandatory.

This section contains a brief summary of the SCSI Interface implemented in the drive. For additional details regarding command descriptions, please refer to the Eleventh Generation SCSI Interface Manual.

SCSI Command Summary

Following is a list of commands that the drive supports:

Format Unit	04H
Inquiry	12H
Mode Select	15H
Mode Sense	1AH
Read (6)	08H
Read Buffer	3CH
Read Capacity	25H
Read Defect Data	37H
Read Extended (10)	28H
Read Long	3EH
Reassign Blocks	07H
Receive Diagnostics	1CH
Release	17H
Request Sense	03H
Reserve	16H
Re-zero Unit	01H
Seek (6)	0BH
Seek Extended (10)	2BH
Send Diagnostic	1DH
Start/Stop Unit	1BH
Test Unit Ready	00H
Verify	2FH
Write (6)	0AH
Write Extended (10)	2AH
Write and Verify	2EH
Write Buffer	3BH
Write Long	3FH

Drive Dependent SCSI Data

The pages which follow show the drive dependent Mode pages. Refer to the Eleventh Generation Disk Drive SCSI-2 Interface Manual for additional information regarding the SCSI implementation. The default values of changeable parameters are noted in parenthesis (). Parameters not specified are 00H.

Format Drive Page - 03H

The Format Drive page contains parameters which specify the medium format.

Table 6-1
Format Drive Page Format

<i>Bit Byte</i>	7	6	5	4	3	2	1	0
0	Rsvd	Rsvd	Page Code = 03 _H					
1	Page Length = 16 _H							
2	Tracks per Zone (MSB) (00 _H)							
3	Tracks per Zone (LSB) (01 _H)							
4	Alternate Sectors per Zone (MSB) (00 _H)							
5	Alternate Sectors per Zone (LSB) (01 _H)							
6	Alternate Tracks per Zone (MSB)							
7	Alternate Tracks per Zone (LSB)							
8	Alternate Tracks per Logical Unit (MSB)							
9	Alternate Tracks per Logical Unit (LSB)							
10	Sectors per Track (MSB) (00 _H)							
11	Sectors per Track (LSB) (7D* _H)							
12	Data Bytes per Physical Sector (MSB) (02 _H)							
13	Data Bytes per Physical Sector (LSB) (00 _H)							
14	Interleave (MSB) (00 _H)							
15	Interleave (LSB) (01 _H)							
16	Track Skew Factor (MSB) (00 _H)							
17	Track Skew Factor (LSB) (0C _H)							
18	Cylinder Skew Factor (MSB) (00 _H)							
19	Cylinder Skew Factor (LSB) (18 _H)							
20	SSEC	HSEC (1)	RMB	SURF	Reserved			
21-23	Reserved							

* Notch 1 (varies depending on active notch).

Tracks Per Zone: Defines the number of tracks per zone to use in dividing the capacity of the drive for the purpose of allocating alternate sectors. A value of zero means that one zone is defined for the entire drive.

Alternate Sectors Per Zone: Defines the number of spare sectors per zone the drive reserves for defect handling. Not supported. Must be set to zero.

Alternate Tracks Per Logical Unit: Not supported. Must be set to zero.

Sectors Per Track: Defines the number of physical sectors per track. The number includes the one alternate sector per track the drive allocates. The value reported for the number of sectors per track is dependent on the active notch value.

Data Bytes Per Physical Sector: Defines the number of data bytes per physical sector.

Interleave: Defines the interleave value used by the drive.

Track Skew Factor: Defines the number of physical sectors between the last logical block of one track, and the first logical block on the next sequential track of the same cylinder.

Cylinder Skew Factor: Specifies the number of physical sectors between the last logical block of one cylinder and the first logical block on the next sequential cylinder.

SSEC (Soft Sector Format): Set to zero to indicate the drive does not support a soft sector format.

HSEC (Hard Sector Format): Set to one to indicate the drive supports a hard sector format.

RMB (Removable Media): Set to zero to indicate the drive does not have removable media.

SURF (Surface Format): The SURF bit is set to zero, meaning the drive allocates progressive addresses to all logical blocks within a cylinder prior to allocating addresses on the next cylinder.

Drive Geometry Page - 04_H**Table 6-2
Drive Geometry Page**

Bit Byte	7	6	5	4	3	2	1	0
0	Rsvd	Rsvd	Page Code = 04 _H					
1	Page Length = 16 _H							
2	Number of Cylinders (MSB) (00 _H)							
3	Number of Cylinders (0F _H)							
4	Number of Cylinders (LSB) (9F _H)							
5	Number of Heads (0A _H)							
6	Starting Cylinder - Write Precompensation (MSB) (00 _H)							
7	Starting Cylinder - Write Precompensation (06 _H)							
8	Starting Cylinder - Write Precompensation (LSB) (00 _H)							
9	Starting Cylinder - Reduced Write Current (MSB)							
10	Starting Cylinder - Reduced Write Current							
11	Starting Cylinder - Reduced Write Current (LSB)							
12	Drive Step Rate (MSB)							
13	Drive Step Rate (LSB)							
14	Landing Zone Cylinder (MSB)							
15	Landing Zone Cylinder							
16	Landing Zone Cylinder (LSB)							
17	Reserved							RPL (0 _H)
18	Rotational Offset							
19	Reserved							
20	Medium Rotation Rate (MSB) (1C _H)							
21	Medium Rotation Rate (LSB) (20 _H)							
22-23	Reserved							

* *Varies depending on active notch.*

Only one copy of this page is maintained. There is only one changeable field, RPL. All other fields are described in the MODE SENSE Command.

RPL (Rotational Position Locking): Enables spindle synchronization. Setting either bit 0 or 1, or both, causes multiple drives which have their spindle synchronization (SS) pins daisy chained together to synchronize their spindles.

Notch and Partition Parameters Page - 0C_H

The Notch and Partition Parameters Page contains information which pertains to each notch of the drive. Each section of the drive with a different number of logical blocks per cylinder is referred to as a notch or zone. Only one copy of this page is maintained. The only changeable field in this page is Active Notch.

Table 6-3
Notch and Partition Parameters Page Format

<i>Bit Byte</i>	7	6	5	4	3	2	1	0
0	Rsvd	Rsvd	Page Code - OC _H					
1	Page Length = 16 _H							
2	ND (1)	LPN	Reserved					
3	Reserved							
4	Maximum Number of Notches (MSB) (00 _H)							
5	Maximum Number of Notches (LSB) (0F _H)							
6	Active Notch (MSB) (00 _H)							
7	Active Notch (LSB) (0 _H) (1* _H)							
8	Starting Boundary (MSB) (00* _H)							
9	Starting Boundary (00* _H)							
10	Starting Boundary (08* _H)							
11	Starting Boundary (LSB) (00* _H)							
12	Ending Boundary (MSB) (00* _H)							
13	Ending Boundary (03* _H)							
14	Ending Boundary (FD* _H)							
15	Ending Boundary (LSB) (00* _H)							
16	3F	Pages Notched (MSB)						38
17	37	Pages Notched						30
18	2F	Pages Notched						28
19	27	Pages Notched						20
20	1F	Pages Notched						18
21	17	Pages Notched						10
22	0F	Pages Notched (10 _H)						08
23	07	Pages Notched (LSB) (08 _H)						00

* Notch 1 (varies depending on active notch).

ND (Notched Drive): If set to zero, the drive is not notched and all other parameters in this page are returned as zeros. If set to one, the drive is notched and this page defines the starting and ending boundaries for each active notch. This parameter is always set to one.

LPN (Logical or Physical Notch): When set to zero, indicates the notch boundaries are physical addresses (i.e., cylinder and head). An LPN bit of one is not supported.

The **Maximum Number of Notches** field indicates the maximum number of notches supported by the drive.

The **Active Notch** field indicates which notch is being referred to by this and subsequent MODE SELECT and MODE SENSE commands, until changed by a later MODE SELECT command. Active notches are numbered beginning from one up to the maximum number of notches.

The **Starting Boundary** field indicates the beginning of the active notch; the three most significant bytes represent the cylinder number and the least significant byte represents the head number.

The **Ending Boundary** field indicates the ending of the active notch; the three most significant bytes represent the cylinder and the least significant byte represents the head number.

The **Pages Notched** field is a bit map of the MODE SELECT page codes which indicates the pages containing parameters that are changed for different notches. The most significant bit of this field corresponds to page code 3F and the least significant bit represents page code 0. If a bit is a one, the corresponding MODE SELECT page contains parameters that are changed for different notches. If a bit is a zero, the corresponding MODE SELECT page parameters are constant for all notches.